

PRELIMINARY MANUAL

“KEEPER” Safety Light Curtain with multi beams

Instruction use and maintenance

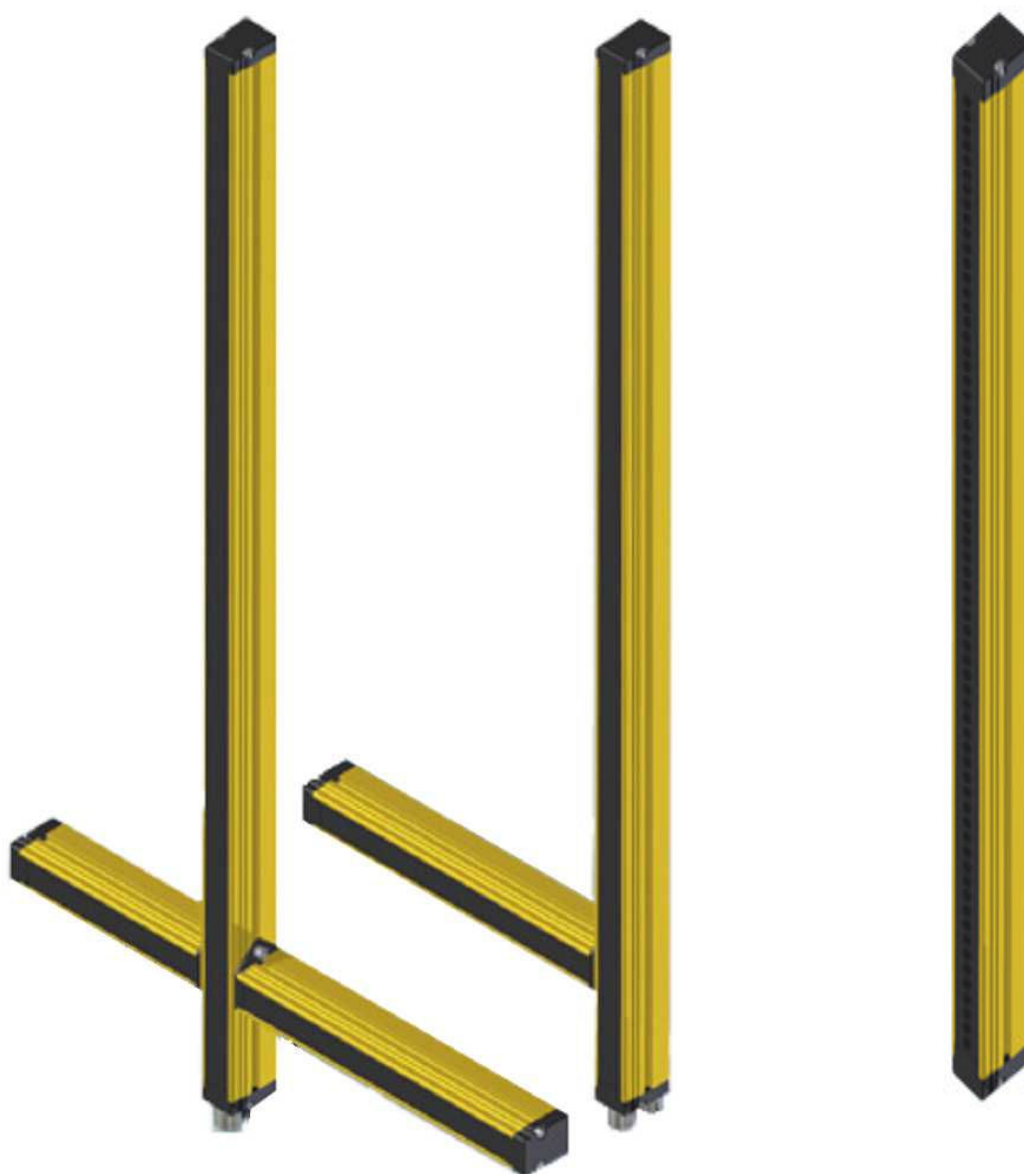

PRELIMINARY MANUAL

IMPORTANT REMARKS ON SAFETY

As this device, for the safety of operators working on dangerous machinery, it is necessary that an authorised person should carry out the installation carefully while making notes, and maintain such records for future instruction and maintenance.

The safety light curtain forms only one link of the safety system.

Therefore, complete system performance remains the responsibility of the machine builder or end user.

Please observe all technical details and recommendations reported in this installation/instruction manual without exception and with strict adherence to all applicable local, National and International Safety Standards and guidelines which may apply to the machines.

GREIN is not responsible for any dangerous occurs to not good employ of the materials.

Summary

GENERAL INFORMATIONS	pag. 4
TERMS AND DEFINITIONS	pag. 4
TECHNICAL CARATTERISTICS / OPTIONS	pag. 5
INSTALLATION GUIDELINES	pag. 6
DETERMINATION OF SAFETY DISTANCE	pag. 7
MINIMUM DISTANCE TO AVOID THE REFLECTIONS	pag. 8
MECHANICAL MOUNTING	pag. 9
GROUPING OF LIGHT CURTAINS	pag. 9
OVERVIEW KEEPER MODELS AND FUNCTIONS	pag. 10
CONFIGURATION - FUNCTIONS - CONNECTIONS	pag. 11
WIRING CONNECTION	pag. 13
EMITTER CONNECTIONS AND FUNCTIONS	pag. 16
RECEIVER CONNECTIONS AND FUNCTIONS	pag. 20
INDICATIONS AND DIAGNOSTIC	pag. 21
SERVICE AND TEST	pag. 24
SETTING UP AND TEST	pag. 25
LIST OF THE MODELS AND THE CHARACTERISTICS	pag. 26
EXTERNAL MUTING DETAILS	pag. 30
INTERNAL MUTING DETAILS	pag. 30
INTERNAL AND EXTERNAL MUTING COMBINATION	pag. 37
MUTING ARM REGULATION	pag. 38
ACCESSORIES - BRACKETS	pag. 39
CONNECTION CABLES	pag. 42
RELAYS MODULE DIN RAIL	pag. 43

GENERAL INFORMATIONS

The KEEPER multibeam safety barrier is an optoelectronic system(**Electro Sensitive Protective Equipment**) type 4 for the protection of worker exposed to dangerous machinery or equipment in accordance with current regulations on industrial safety.

KEEPER is formed by a transmitter and a receiver unit synchronized through a optical link. The safety outputs are solid state with the possibility to convert them into outputs relays using the appropriate optional modules. Are available interconnect modules to interface directly with the barrier without going through the electrical cabinet.

The advanced possibilities of the muting make this safety barriers ideal in automatic handling and storage. The wide range of models allows their use for the protection of the fingers, hand, arm and body. The main areas of application are: robotized areas, palletizers, automated warehouses, etc.

TERMS AND DEFINITIONS

OSSD0	Safety output channel zero.
OSSD1	Safety output channel one.
OSSD STATO ON	Condition on which the output permits the flow of current.
OSSD STATO OFF	Condition on which the output don't permit the flow of current.
EDM	External Device Monitor.
RESET	OSSD restart from OFF to ON.
MUTING	Temporary suspension of the safety function.
OVERRIDE	Manual muting function after a mistake in automatic muting.

Protective height	PH It is the zone in which the test rod will stop the barrier.
Sensitive height	SH It is the zone covered by the beams.
A	Active part of the lens.
B	Beam spacing in mm.
Resolution	d It is the minimum object detected on protected area, Is the dimension necessary for the obscuration of two adjacent beams. d = A + B .

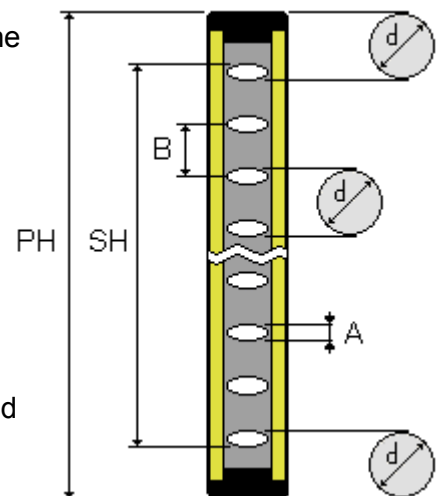

Technical characteristics and Functions

Synchronization Tx Rx	Optical
Total aperture angle	5°
Wave length	850nm
Resolutions	14, 30, 55, 175, 320 mm
Maximum range	0.5 - 2.5m across beam muting, 0.5 - 5m parallel beam muting
Power supply	24Vcc ± 10% PELV
Response time	From 6 to 16ms depending to number of beams
Max connections lenght	100 m
Body	Extruded aluminium, 36 x 50, yellow RAL 1.021
IP protection degree	IP 65
Relative umidity	5 ÷ 95%
Working temperature	0 ÷ 65 °C
Safety level	Typo 4 - SIL 3 - SILCL 3 - PL e - Cat. 4
Emitter	
Connector	M12 5 poli
TEST	Simulation of interruption of light curtain beams barrier, to facilitate the monitoring of the safety of the machine
Receiver	
Connector	M12 5 + 8 poles or M23 17 poles depend of the model and options
Reset	Selection of the restart of the barrier
Type	Automatic or manual
Restart time	100ms
Static Output	2 PNP - 500 mA short circuit and overload protected
EDM	Controllo teleruttori esterni
BARGRAPH	a 3 led per Indicazione di allineamento e diagnostica
External Muting type	Two sensors, with contemporaneity control
Override	Manual override of muting function
Muting lamp output	Output for muting lamp, 24V 500mA max

Other functions

MUTING	Temporary exclusion of the light curtain
Internal muting LX	L with 2 sensors, contemporaneity muting activation
Internal muting LP	L with 2 sensors, sequential muting activation
Internal muting TX	T with 2 sensors, contemporaneity muting activation
Internal muting TP	T with 4 sensors, sequential muting activation
Muting enable	Muting function enable
OSSD-S	Output signaling of the safety outputs state
MUTE - F	Output for signaling of interrupted barrier when muting is active

INSTALLATION GUIDELINES

Correct Installations

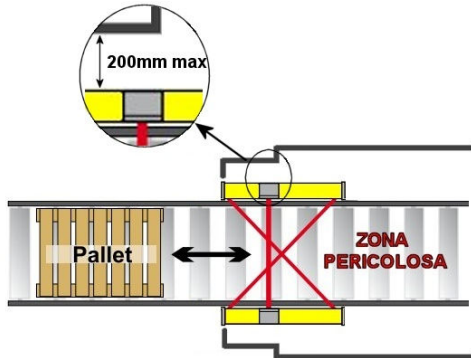

T model with across beams(entry or exit)

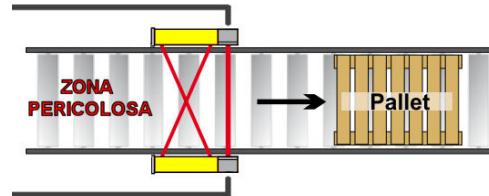

L model with across beams(exit)

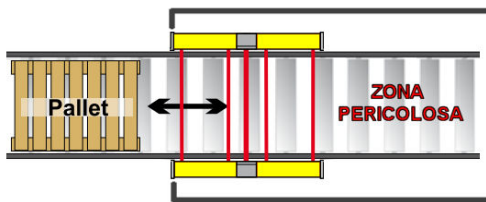

T model with parrallel beams(entry or exit)

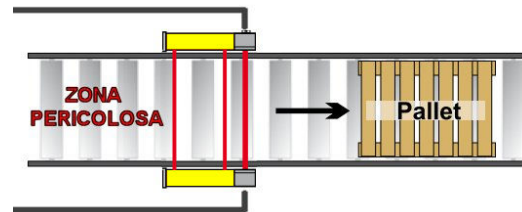

L model with parallel beams(exit)

Incorrect installations

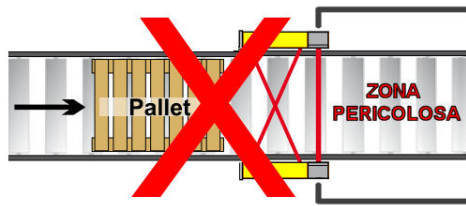

L - Incorrect use in entry

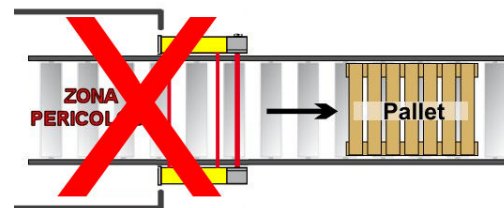

Insufficient mechanical protection

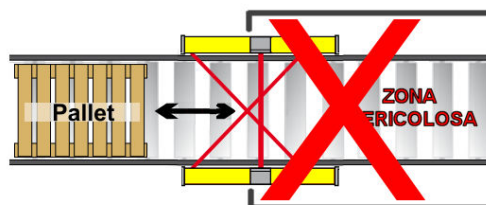

Wrong orientation T crossed beams

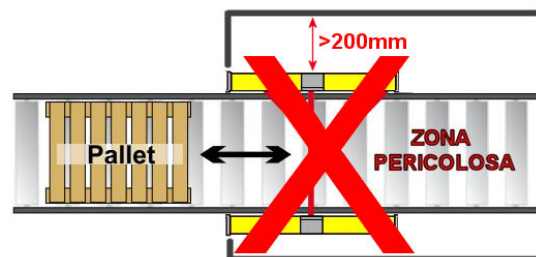

Mechanical protection incorrect

DETERMINATION OF SAFETY DISTANCE

Before of the installation it is necessary to calculate the safety distance in order to allow the stop of the machine before the operator enter in the dangerous area (as described in EN 999 and ISO 13855).

Definitions:

- S** safety distance in mm
- T1** response time of machine in msec
- T2** response time of curtain in msec
(see TX / RX label)
- d** resolution of the system in mm

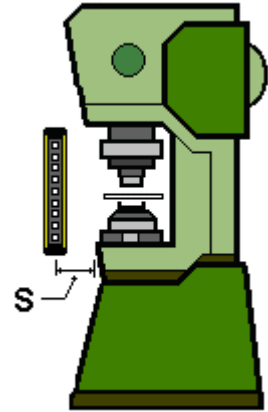

Vertical installation

Models with resolution up to 40mm

The following formula is valid for a distance S included between 100 and 500 mm :

$$S = 2 (T1 + T2) + 8 (d - 14)$$

If **S** results more of 500mm, use the following formula :

$$S = 1,6 (T1 + T2) + 8 (d-14)$$

Models with resolution more than 40 and up to 90 mm

$$S = 1,6 (T1 + T2) + 850$$

The highest beam must be placed at a minimum height of 900 mm from the installation plane of the machine, while the inferior beam must be at a height less than 300 mm

Models with resolution more than 90 mm

$$S = 1,6 (T1 + T2) + 1.200$$

For applications on packaging machines (eg palletizers) must be complied with the instructions provided in the standard EN415-4.

MINIMUM DISTANCE TO AVOID THE REFLECTIONS

The beam angle of optic and alignment tolerance for emitter and receiver is 5 degrees. Since reflective surfaces within the detection zone can lead to deflection and therefore non-detection of an object, a minimum distance A to the optical axis, should be observed according to the following formula:

$$A = 44 L \quad \text{where } A \text{ is in mm} \quad L \text{ is in m}$$

A should never be less than 131mm

To verify the above, after installation of the light curtain, set the automatic reset, pass the test rod through the detection zone, and verify that the green LED remain always OFF. If the green led in some cases goes in ON state modify the position of the barrier in order to avoid the reflection.

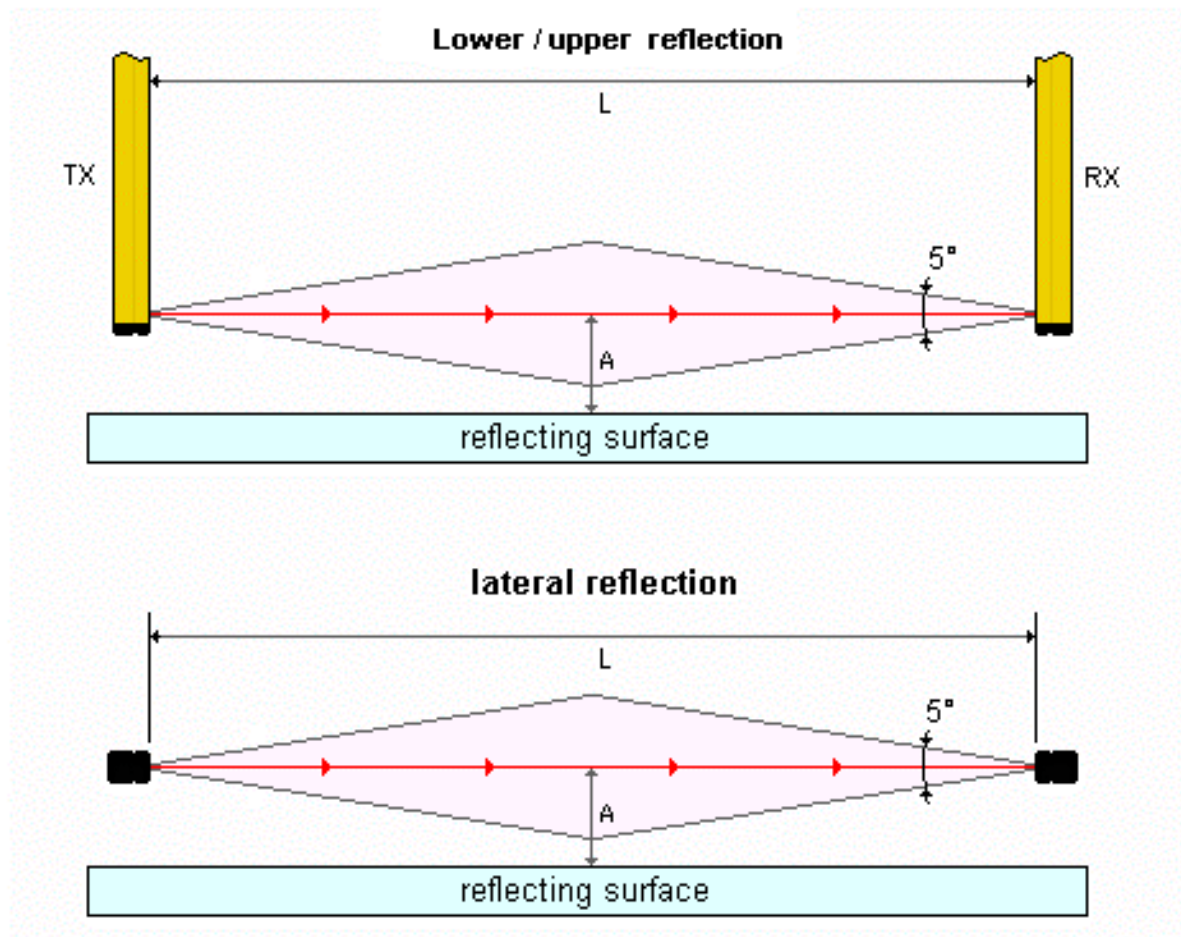

MECHANICAL ASSEMBLY

During the installation it is necessary to verify the right position of emitter and receiver in order to check that they are in the same plane and axis as shown on the following drawings.

SIDE VIEW:

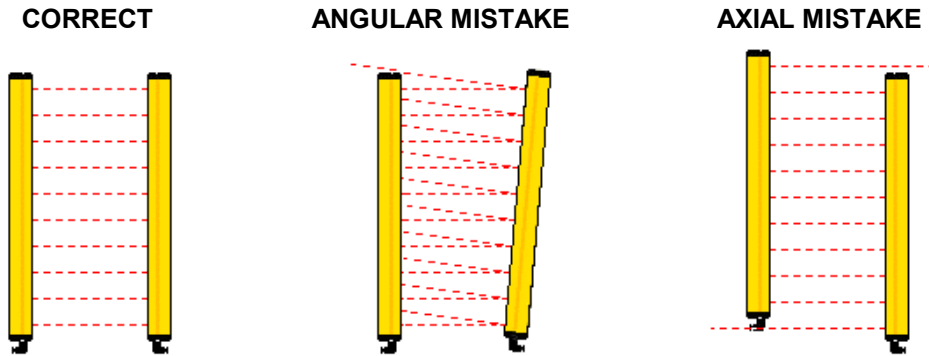

TOP VIEW:



GROUPING OF LIGHT CURTAINS

Directions to avoid interference between light curtains assembled in line in case of long distances or protected machines installed in series:

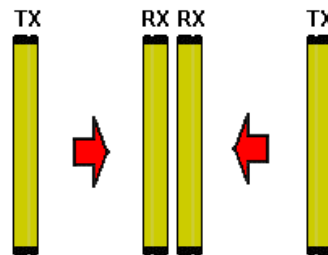

The light curtain can work on vertical position or upside-down. Don't turn the transmitter in the opposite direction to the receiver because it changes the protected field.

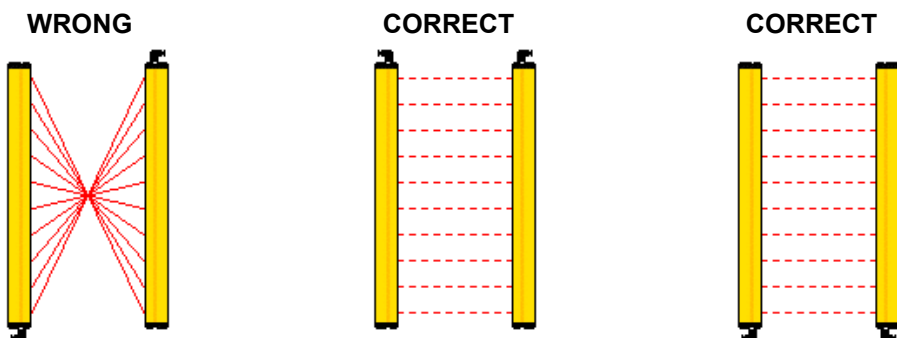

OVERVIEW KEEPER MODELS AND FUNCTIONS

The peculiar characteristic is the presence of MUTING arms that include the sensors with fixed detection geometries. The MUTING arms, can be mobile with the possibility of vertical/angular adjustment during installation (XXM series), or fixed without adjustment (XXF series) or vertical execution with the possibility of external muting sensors connection chosen by the customer (series XXi).

TPM, TXM, LPM, LXM

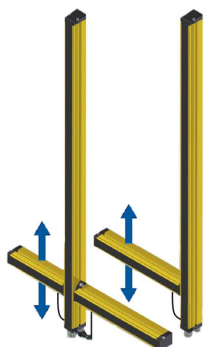

TPF, TXF, LPF, LXF

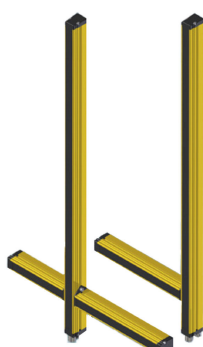

T Pi, TXi, LPi, LXi



May be provided in the configuration T for the control of entry and exit, or L for the exit control. The beams sensors can be configured in parallel or crossed configuration.

In the version with **parallel** MUTING sensors, the muting is active when the correct sequence of interruption of the beams sensors is performed. The maximum distance between TX and RX is 5m, the material being processed can interrupt the muting sensors in any direction of the movement.

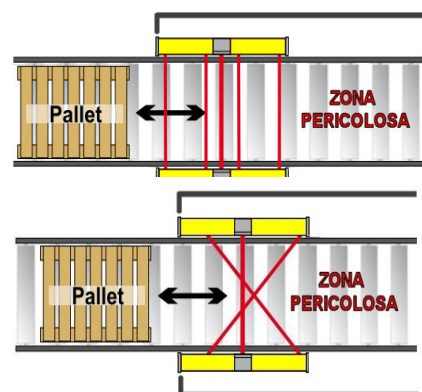

In the version with **crossed** muting sensors, the muting is active when the beams muting sensors are interrupted simultaneous. The maximum distance between TX and RX is 2.5m, the material being processed must interrupt the muting sensors in the central area.

For all model there is:

- TEST input TEST on the TX unit;
- RESTART manual and automatic restart;
- EDM external device monitoring;
- BARGRAPH 3 led for alignment and indications;
- GOVR 0-1 guard-override functions
- MUTE-S output muting lamp.

Depending on the model chosen, there are the following additional features:

- MUTE-E MUTING enable;
- O-S output signalling OSSD status;
- M-F output signaling vertical barrier interrupted during the MUTING function;
- MUTE 0-1 external MUTING(2 input sensors + guard override + lamp output);
- MUTE-T selection of the duration of the MUTING(1 minutes, 90 minutes, 24 hour).

CONFIGURATIONS/FUNCTIONS KEEPER MOBILE ARMS

KEEPER with mobile arms									
Model	Description	Functions					RX connections		
		MUTE-E	TIME	MUTE0-1	O-S	M-F	M12 5Poli	M12 8Poli	M23 17Poli
L 2 sensors with crossed beams									
KP-e ... - LXM 1	2 mobile sensors with crossed beams / Rx right			•			•	•	
KP-f1 ... - LXM 1	2 mobile sensors with crossed beams / Rx right	•		•	•				•
KP-f2 ... - LXM 1	2 mobile sensors with crossed beams / Rx right	•		•		•			•
KP-g1 ... - LXM 1	2 mobile sensors with crossed beams / Rx right	•	•			•			•
KP-g2 ... - LXM 1	2 mobile sensors with crossed beams / Rx right	•	•			•			•
KP-e ... - LXM 2	2 mobile sensors with crossed beams / Rx left			•			•	•	
KP-f1 ... - LXM 2	2 mobile sensors with crossed beams / Rx left	•		•					•
KP-f2 ... - LXM 2	2 mobile sensors with crossed beams / Rx left	•		•		•			•
KP-g1 ... - LXM 2	2 mobile sensors with crossed beams / Rx left	•	•			•			•
KP-g2 ... - LXM 2	2 mobile sensors with crossed beams / Rx left	•	•			•			•
L 2 sensors with parallel beams									
KP-e ... - LPM 1	2 mobile sensors with parallel beams / Rx right			•			•	•	
KP-f1 ... - LPM 1	2 mobile sensors with parallel beams / Rx right	•		•	•				•
KP-f2 ... - LPM 1	2 mobile sensors with parallel beams / Rx right	•		•		•			•
KP-g1 ... - LPM 1	2 mobile sensors with parallel beams / Rx right	•	•		•				•
KP-g2 ... - LPM 1	2 mobile sensors with parallel beams / Rx right	•	•			•			•
KP-e ... - LPM 2	2 mobile sensors with parallel beams / Rx left			•			•	•	
KP-f1 ... - LPM 2	2 mobile sensors with parallel beams / Rx left	•		•	•				•
KP-f2 ... - LPM 2	2 mobile sensors with parallel beams / Rx left	•		•		•			•
KP-g1 ... - LPM 2	2 mobile sensors with parallel beams / Rx left	•	•		•				•
KP-g2 ... - LPM 2	2 mobile sensors with parallel beams / Rx left	•	•			•			•
T 2 sensors with crossed beams									
KP-e ... - TXM 1	2 mobile sensors with crossed beams / Rx right			•			•	•	
KP-f1 ... - TXM 1	2 mobile sensors with crossed beams / Rx right	•		•	•				•
KP-f2 ... - TXM 1	2 mobile sensors with crossed beams / Rx right	•		•		•			•
KP-g1 ... - TXM 1	2 mobile sensors with crossed beams / Rx right	•	•			•			•
KP-g2 ... - TXM 1	2 mobile sensors with crossed beams / Rx right	•	•			•			•
KP-e ... - TXM 2	2 mobile sensors with crossed beams / Rx left			•			•	•	
KP-f1 ... - TXM 2	2 mobile sensors with crossed beams / Rx left	•		•	•				•
KP-f2 ... - TXM 2	2 mobile sensors with crossed beams / Rx left	•		•		•			•
KP-g1 ... - TXM 2	2 mobile sensors with crossed beams / Rx left	•	•		•				•
KP-g2 ... - TXM 2	2 mobile sensors with crossed beams / Rx left	•	•			•			•
T 4 sensors with parallel beams									
KP-e ... - TPM 3	4 mobile sensors with parallel beams			•			•	•	
KP-f1 ... - TPM 3	4 mobile sensors with parallel beams	•		•	•				•
KP-f2 ... - TPM 3	4 mobile sensors with parallel beams	•		•		•			•
KP-g1 ... - TPM 3	4 mobile sensors with parallel beams	•	•			•			•
KP-g2 ... - TPM 3	4 mobile sensors with parallel beams	•	•			•			•

... optical code, see detail on page 31 - 33

LEGEND

- MUTE-E input for muting enable.
- TIME inputs for selection of the duration of the MUTING.
- MUTE 0-1 inputs for external muting sensors.
- O-S output signalling OSSD status.
- M-F output signaling vertical barrier interrupted during the MUTING function.

RX right and left are referred to the position of the receiver observing the area protected from the outside to the danger zone.

CONFIGURATIONS/FUNCTIONS KEEPER FIXED ARMS

KEEPER with fixed arms									
Model	Description	Functions					RX connections		
		MUTE-E	TIME	MUTE0-1	O-S	M-F	M12 5Poli	M12 8Poli	M23 17Poli
L 2 sensors with crossed beams									
KP-e ... -LXF 1	2 mobile sensors with crossed beams / Rx right			•			•	•	
KP-f1 ... -LXF 1	2 mobile sensors with crossed beams / Rx right	•		•	•				•
KP-f2 ... -LXF 1	2 mobile sensors with crossed beams / Rx right	•		•		•			•
KP-g1 ... -LXF 1	2 mobile sensors with crossed beams / Rx right	•	•			•			•
KP-g2 ... -LXF 1	2 mobile sensors with crossed beams / Rx right	•	•			•			•
KP-e ... -LXF 2	2 mobile sensors with crossed beams / Rx left			•			•	•	
KP-f1 ... -LXF 2	2 mobile sensors with crossed beams / Rx left	•		•					•
KP-f2 ... -LXF 2	2 mobile sensors with crossed beams / Rx left	•		•		•			•
KP-g1 ... -LXF 2	2 mobile sensors with crossed beams / Rx left	•	•			•			•
KP-g2 ... -LXF 2	2 mobile sensors with crossed beams / Rx left	•	•			•			•
L 2 sensors with parallel beams									
KP-e ... -LPF 1	2 mobile sensors with parallel beams / Rx right			•			•	•	
KP-f1 ... -LPF 1	2 mobile sensors with parallel beams / Rx right	•		•	•				•
KP-f2 ... -LPF 1	2 mobile sensors with parallel beams / Rx right	•		•		•			•
KP-g1 ... -LPF 1	2 mobile sensors with parallel beams / Rx right	•	•		•				•
KP-g2 ... -LPF 1	2 mobile sensors with parallel beams / Rx right	•	•			•			•
KP-e ... -LPF 2	2 mobile sensors with parallel beams / Rx left			•			•	•	
KP-f1 ... -LPF 2	2 mobile sensors with parallel beams / Rx left	•		•	•				•
KP-f2 ... -LPF 2	2 mobile sensors with parallel beams / Rx left	•		•		•			•
KP-g1 ... -LPF 2	2 mobile sensors with parallel beams / Rx left	•	•		•				•
KP-g2 ... -LPF 2	2 mobile sensors with parallel beams / Rx left	•	•			•			•
T 2 sensors with crossed beams									
KP-e ... -TXF 1	2 mobile sensors with crossed beams / Rx right			•			•	•	
KP-f1 ... -TXF 1	2 mobile sensors with crossed beams / Rx right	•		•	•				•
KP-f2 ... -TXF 1	2 mobile sensors with crossed beams / Rx right	•		•		•			•
KP-g1 ... -TXF 1	2 mobile sensors with crossed beams / Rx right	•	•			•			•
KP-g2 ... -TXF 1	2 mobile sensors with crossed beams / Rx right	•	•			•			•
KP-e ... -TXF 2	2 mobile sensors with crossed beams / Rx left			•			•	•	
KP-f1 ... -TXF 2	2 mobile sensors with crossed beams / Rx left	•		•	•				•
KP-f2 ... -TXF 2	2 mobile sensors with crossed beams / Rx left	•		•		•			•
KP-g1 ... -TXF 2	2 mobile sensors with crossed beams / Rx left	•	•			•			•
KP-g2 ... -TXF 2	2 mobile sensors with crossed beams / Rx left	•	•			•			•
T 4 sensors with parallel beams									
KP-e ... -TPF 3	4 mobile sensors with parallel beams			•			•	•	
KP-f1 ... -TPF 3	4 mobile sensors with parallel beams	•		•	•				•
KP-f2 ... -TPF 3	4 mobile sensors with parallel beams	•		•		•			•
KP-g1 ... -TPF 3	4 mobile sensors with parallel beams	•	•			•			•
KP-g2 ... -TPF 3	4 mobile sensors with parallel beams	•	•			•			•

... optical code, see detail on page 31 - 33

LEGEND

- MUTE-E input for muting enable.
- TIME inputs for selection of the duration of the MUTING.
- MUTE 0-1 inputs for external muting sensors.
- O-S output signalling OSSD status.
- M-F output signaling vertical barrier interrupted during the MUTING function.

RX right and left are referred to the position of the receiver observing the area protected from the outside to the danger zone.

CONFIGURATIONS/FUNCTIONS KEEPER EXTERNAL MUTING SENSORS

KEEPER with external muting sensors									
Model	Description	Functions					RX Connections		
		MUTE-E	TIME	MUTE0-1	O-S	M-F	M12 5Poli	M12 8Poli	M23 17Poli
L 2 sensors with crossed beams									
KP-e ... - LXi 3	2 external sensors with crossed beams			•			•	•	
KP-f1 ... - LXi 3	2 external sensors with crossed beams	•		•	•				•
KP-f2 ... - LXi 3	2 external sensors with crossed beams	•		•		•			•
KP-g1 ... - LXi 3	2 external sensors with crossed beams	•	•			•			•
KP-g2 ... - LXi 3	2 external sensors with crossed beams	•	•						•
L 2 sensors with parallel beams									
KP-e ... - LPi 3	2 external sensors with parallel beams			•			•	•	
KP-f1 ... - LPi 3	2 external sensors with parallel beams	•		•	•				•
KP-f2 ... - LPi 3	2 external sensors with parallel beams	•		•		•			•
KP-g1 ... - LPi 3	2 external sensors with parallel beams	•	•			•			•
KP-g2 ... - LPi 3	2 external sensors with parallel beams	•	•						•
T 2 sensors with crossed beams									
KP-e ... - TXi 3	2 external sensors with crossed beams			•			•	•	
KP-f1 ... - TXi 3	2 external sensors with crossed beams	•		•	•				•
KP-f2 ... - TXi 3	2 external sensors with crossed beams	•		•		•			•
KP-g1 ... - TXi 3	2 external sensors with crossed beams	•	•			•			•
KP-g2 ... - TXi 3	2 external sensors with crossed beams	•	•						•
T 4 sensors with parallel beams									
KP-e ... - TPi 3	4 external sensors with parallel beams			•			•	•	
KP-f1 ... - TPi 3	4 external sensors with parallel beams	•		•	•				•
KP-f2 ... - TPi 3	4 external sensors with parallel beams	•		•		•			•
KP-g1 ... - TPi 3	4 external sensors with parallel beams	•	•			•			•
KP-g2 ... - TPi 3	4 external sensors with parallel beams	•	•						•

... optical code, see detail on page 31 - 33

LEGEND

MUTE-E	input for muting enable.
TIME	inputs for selection of the duration of the MUTING.
MUTE 0-1	inputs for external muting sensors.
O-S	output signalling OSSD status.
M-F	output signaling vertical barrier interrupted during the MUTING function.

CONNECTIONS

TRANSMITTER

M12-4P M12 - 4 poles - male connector

RICEIVER

M12-5P M12 - 5 poles - male connector

M12-8P M12 - 8 poles - male connector

M23-17P M23 - 17 poles - male connector

WIRING CONNECTION

Warning on connection cables

- 1 - Use cables with section of 1 mm² for length connection more than 50m.
- 2 - The units TX / RX shall be connect to the ground (PE).
- 3 - All the cables shall follow different way from those of power.
- 4 - The power of the barrier should be separated from that of equipment dedicated to the control of power equipment, such as inverters.
- 5 - If there is the possibility to damage the cables, take care to protect them against crushing or cutting.
- 6 - The cables should be shielded type, the shield should be connected to the ground (PE).

KP Emitter connections

Emitter		KP - ... -				
Pin N	Wire color	Function	Description	Type	Level	
M12 4 poles						
1	Brown	+24V	Positive power supply	IN	+24Vdc +/- 10% 0,5A	
2	White	TEST	TEST signal	IN	0 - 24 Vdc 10mA	
3	Blue	GND	0V power supply	IN	0V	
4	Black	PE	Ground	-	-	

Example of connection

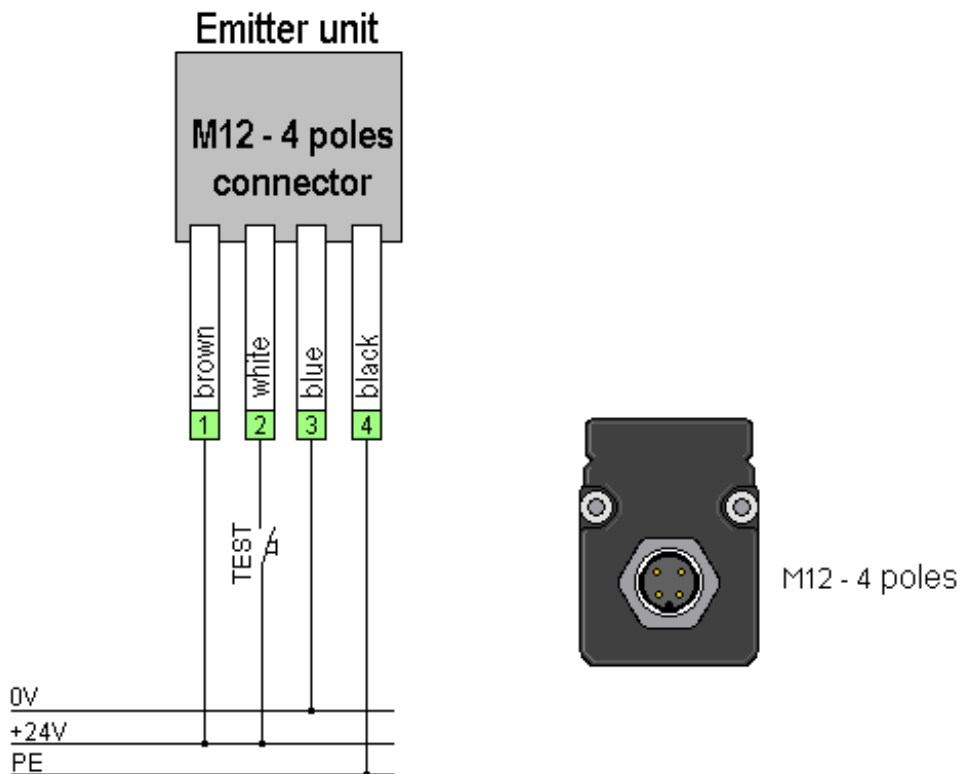

KP - e RECEIVER CONNECTIONS

Receiver		EF-e - ...	Reset + Edm + Muting			
Pin N	Wire color	Function	Description	Type	Level	
M12 8 poles						
1	White	OSSD-0	Static output safety 0	OUT	0 - 24 Vdc	0,5A max
2	Brown	+24V	Positive power supply	IN	+24 Vdc +/- 10%	1A
3	Green	START ENABLE	Selection of manual or automatic reset	IN	0 - 24 Vdc	10mA
4	Yellow	START	Input of external RESET	IN	0 - 24 Vdc	10mA
5	Grey	OSSD-1	Static output safety 1	OUT	0 - 24 Vdc	0,5A max
6	Pink	EDM	External device monitor input	IN	0 - 24 Vdc	10mA
7	Blue	GND	0V power supply	IN	0V	
8	Red	PE	Ground	-	-	
M12 5 poles						
1	Brown	GOVR-0	Guard override input 0, bypass of the muting function	IN	0 - 24 Vdc	10mA
2	White	GOVR-1	Guard override input1, bypass of the muting function	IN	0 - 24 Vdc	10mA
3	Blue	MUTE-0	Muting 0 input	IN	0 - 24 Vdc	10mA
4	Black	MUTE-1	Muting 1 input	IN	0 - 24 Vdc	10mA
5	Grey	MUTE-S	Muting lamp output	OUT	0 - 24 Vdc	0,5A max

Example of connections

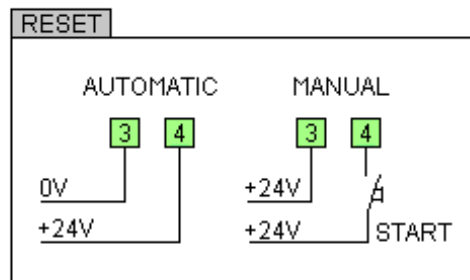
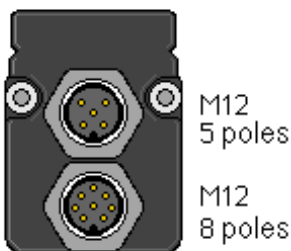
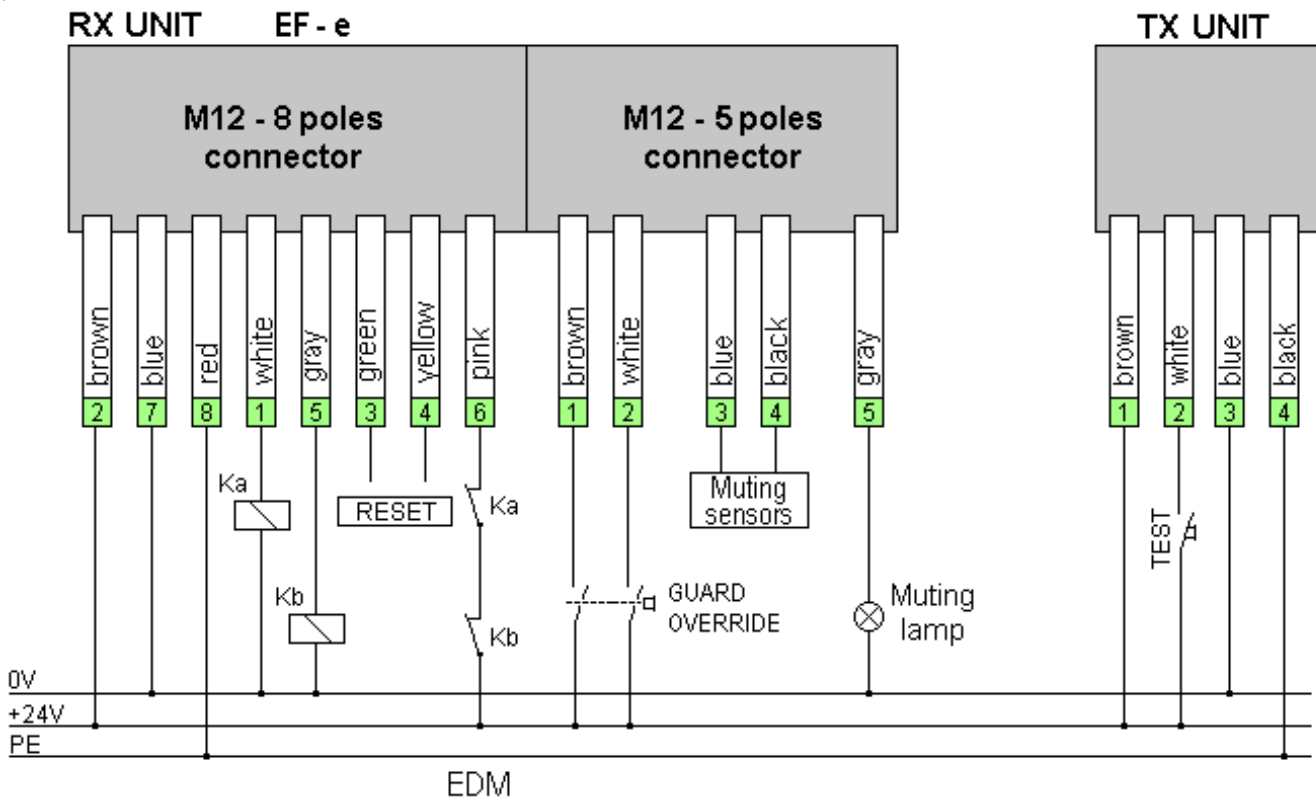

KP - f1 / KP - f2 RECEIVER CONNECTIONS

Receiver		EF-f - ...	Reset + Edm + Muting			
Pin N	Wire color	Function	Description	Type	Level	
M23 17 poles						
1	White	OSSD-0	Static output safety 0	OUT	0 - 24 Vdc	0,5A max
2	Brown	+24V	Positive power supply	IN	+24 Vdc +/- 10%	1A
3	Green	START ENABLE	Selection of manual or automatic reset	IN	0 - 24 Vdc	10mA
4	Yellow	START	Input of external RESET	IN	0 - 24 Vdc	10mA
5	Grey	OSSD-1	Static output safety 1	OUT	0 - 24 Vdc	0,5A max
6	Pink	EDM	External device monitor input	IN	0 - 24 Vdc	10mA
7	Blue	GND	0V power supply	IN	0V	
8	Red	PE	Ground	-	-	
9	Black	Nc		-	-	
10	Purple	OSSD-S MUTE-F	EF f1 = OSSD-S Output signaling of the safety outputs state EF f2 = MUTE - F main beam interrupted when MUTING function is activated	OUT	0 - 24 Vdc	0,2A max
11	Grey - pink	GOVR-0	Guard override input 0, bypass of the muting function	IN	0 - 24 Vdc	10mA
12	Red - blue	GOVR-1	Guard override input 1, bypass of the muting function	IN	0 - 24 Vdc	10mA
13	White - green	MUTE-0	Muting 0 input	IN	0 - 24 Vdc	10mA
14	Brown - green	MUTE-1	Muting 1 input	IN	0 - 24 Vdc	10mA
15	White - yellow	MUTE-S	Muting lamp output	OUT	0 - 24 Vdc	0,5A max
16	Yellow - brown	MUTE-E	Muting function enable	IN	0 - 24 Vdc	10mA
17	White - grey	nc		-	-	

Example of connections

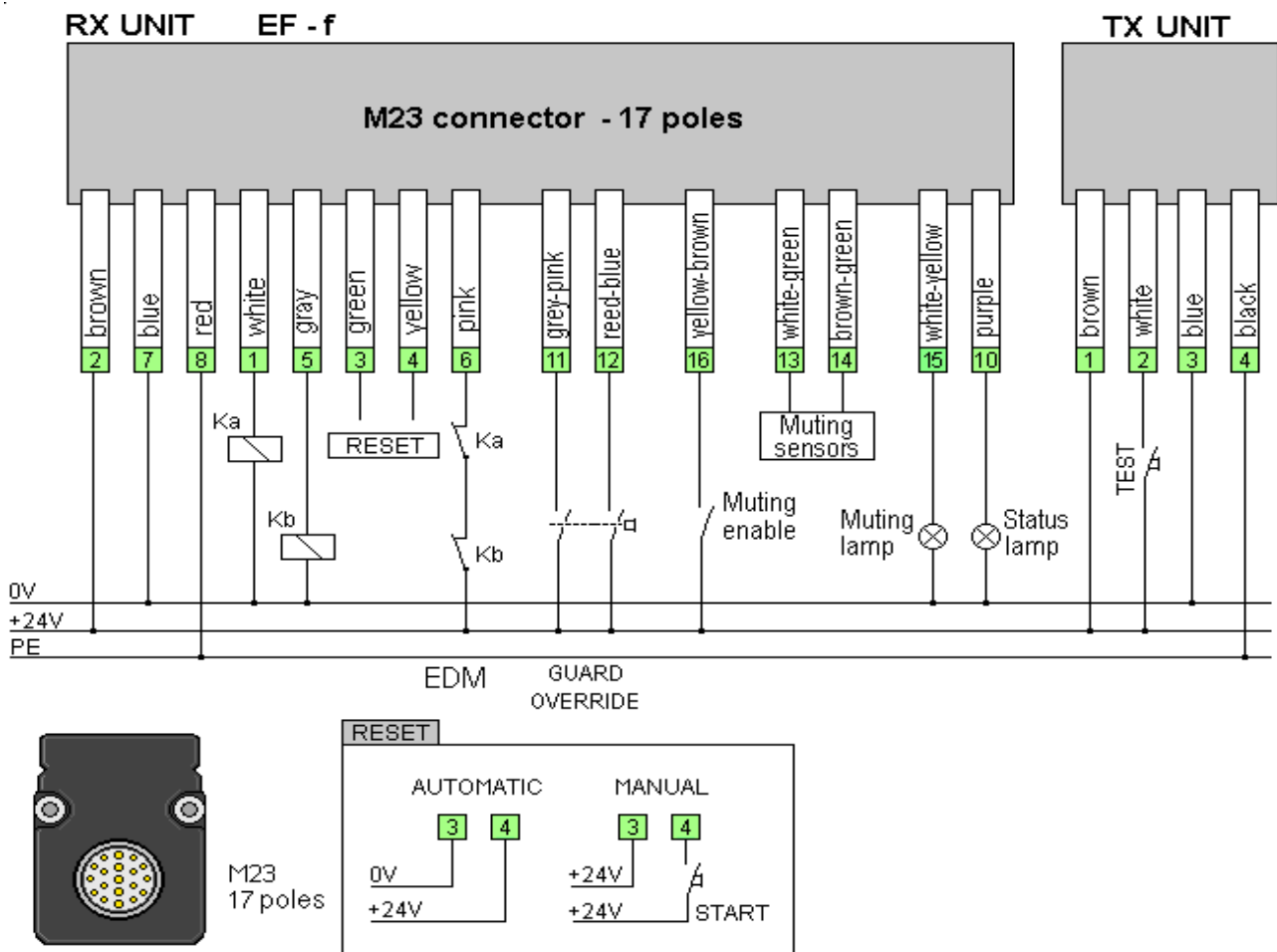

KP - g1 / KP - g2 RECEIVER CONNECTIONS

Receiver		EF-g - ...	Reset + Edm + Muting			
Pin N	Wire color	Function	Description	Type	Level	
M23 17 poles						
1	White	OSSD-0	Static output safety 0	OUT	0 - 24 Vdc	0,5A max
2	Brown	+24V	Positive power supply	IN	+24 Vdc +/- 10%	1A
3	Green	START ENABLE	Selection of manual or automatic reset	IN	0 - 24 Vdc	10mA
4	Yellow	START	Input of external RESET	IN	0 - 24 Vdc	10mA
5	Grey	OSSD-1	Static output safety 1	OUT	0 - 24 Vdc	0,5A max
6	Pink	EDM	External device monitor input	IN	0 - 24 Vdc	10mA
7	Blue	GND	0V power supply	IN	0V	
8	Red	PE	Ground	-	-	
9	Black	Nc		-	-	
10	Purple	OSSD-S MUTE-F	EF G1 = OSSD-S Output signaling of the safety outputs state EF G2 = MUTE - F main beam interrupted when MUTING function is activated	OUT	0 - 24 Vdc	0,2A max
11	Grey - pink	GOVR-0	Guard override input 0, bypass of the muting function	IN	0 - 24 Vdc	10mA
12	Red - blue	GOVR-1	Guard override input 1, bypass of the muting function	IN	0 - 24 Vdc	10mA
13	White - green	TIME-0	Time configuration input 0	IN	0 - 24 Vdc	10mA
14	Brown - green	TIME-1	Time configuration input 1	IN	0 - 24 Vdc	10mA
15	White - yellow	MUTE-S	Muting lamp output	OUT	0 - 24 Vdc	0,5A max
16	Yellow - brown	MUTE-E	Muting function enable	IN	0 - 24 Vdc	10mA
17	White - grey	nc		-	-	

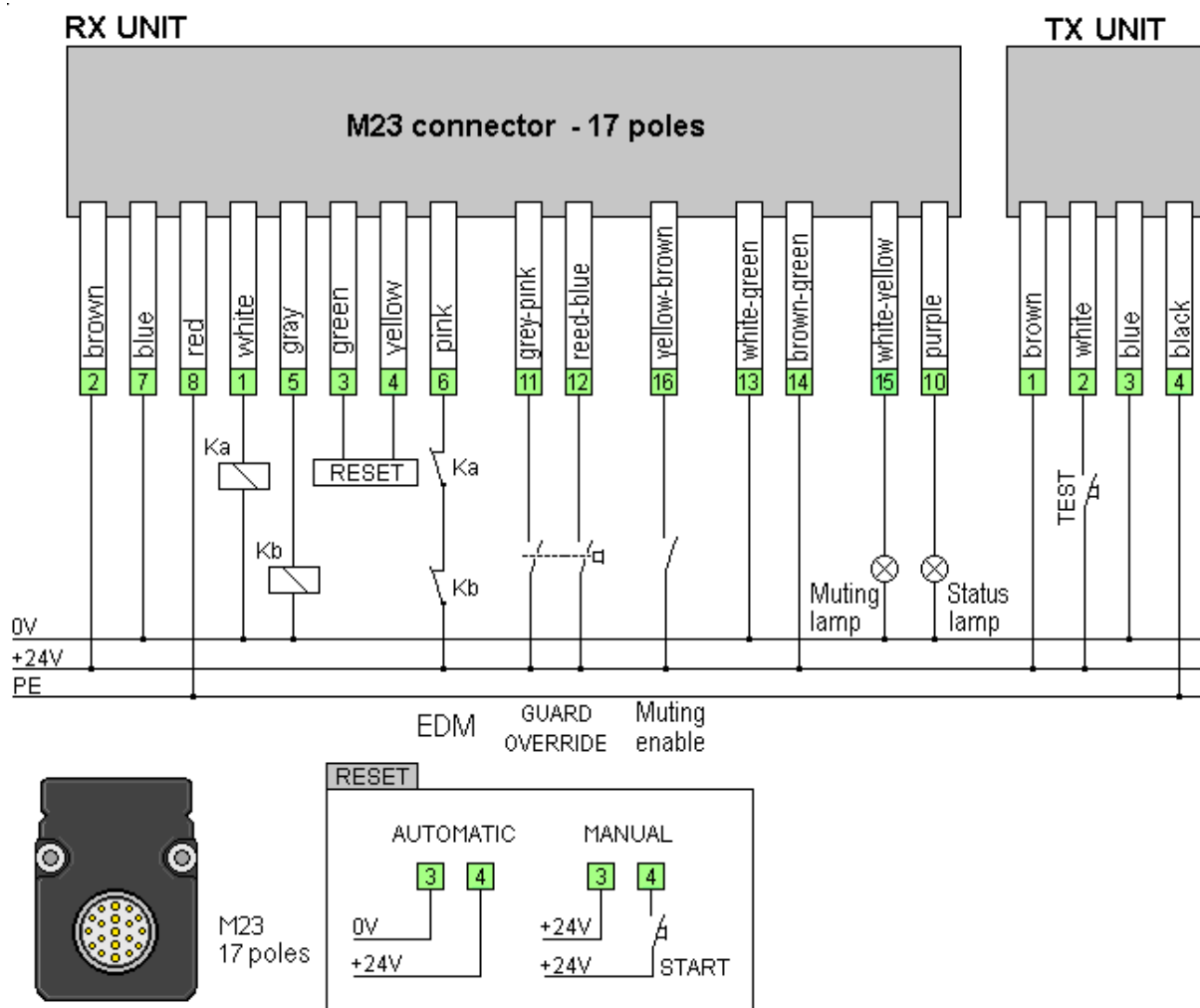

EMITTER CONNECTIONS AND FUNCTIONS

+24 Vdc	+24 Vdc Power supply
----------------	----------------------

Connect to +24Vdc PELV $\pm 10\%$ 1A power supply.
The current of 1A is the supply current for all type of KEEPER light curtains.

0 Vdc	0 Vdc Power supply
--------------	--------------------

Connect to 0 Vdc of 24 Vdc PELV $\pm 10\%$ 1A power supply.

PE	Protective Earth
-----------	------------------

Connect to the ground of machine.

TEST	Input for TEST
-------------	----------------

This signal simulates the interruption of the beams to check the safety chain.
During the test, OSSD0 and OSSD1 are in OFF state and the POWER / TEST indicator blinks.
The TEST is active when connected to +24 Vdc.
If connected to 0V or not connected the test is not active, the POWER / TEST indicator is OFF.

RECEIVER CONNECTIONS AND FUNCTIONS

Some of the following functions can be present or not, depending of the model ordered.

Power supply

+24 Vdc	+24 Vdc Power supply
----------------	----------------------

Connect to +24Vdc PELV $\pm 10\%$ 1A power supply.
The current of 1A is the supply current for the KEEPER light curtains.

To calculate the total current is necessary include:

- OSSD0 e OSSD1 absorbed current (max 0.5A each);
- STATUS lamp absorbed current (max 0.2A);
- MUTING lamp absorbed current (max. 0.5 A).

0 Vdc	0 Vdc Power supply
--------------	--------------------

Connect to 0 Vdc of 24 Vdc PELV $\pm 10\%$ 1A power supply.

PE	Protective Earth
-----------	------------------

Connect to the ground of machine.

Outputs

OSSD-0	Safety output 0
OSSD-1	Safety output 1

Static safety PNP outputs, OSSD0(channel 0) and OSSD1(channel 1).

Use the OSSD0 and OSSD1 outputs to stop the dangerous movement of the machine through contactors with guided contacts controlled by the barrier, or by safety relay module or safety PLC.

The OSSDs outputs go in ON state (+24 V) if are satisfy the following conditions:

- barrier aligned and activated by reset command,
- protected area free,
- correct connections and no internal fault.

The barriers with MUTING can activate the OSSDs also using the guard override function.

The OSSD outputs go or remain in OFF state (0Vdc) if it is not satisfied one ore more of the above conditions.

The outputs are dynamically monitored. To check the absence of fault, when the OSSDs are in ON state, will be switched in OFF state for 0,2msec with a period equal to the response time.

ELECTRICAL CHARACTERISTICS OF THE OUTPUTS

DESCRIPTION	
Nominal output current for resistive load	500 mA
Max. output current for resistive load	500 mA
Nominal output current for inductive load	500 mA
Max. output current for inductive load	500 mA
Max. capacitive load with no resistive load applied	10 nF
Max. capacitive load with resistive load of 48 OHM applied	2 uF
Max. output voltage in OFF-State	0.1 V
Max. output current in OFF-State	10 µA (leakage current)
Max. resistance between the OSSDs outputs and the load	22 Ω

OSSD-S	Output for OSSD state
---------------	-----------------------

PNP output to indicate the state of the OSSDs outputs.

This output is 24V when the OSSDs are active, vice versa 0V.

EDM	Input for External Device Monitor
------------	-----------------------------------

Monitoring of external contactors.

Allow to check the external contactors using their series of the NC contacts.

The contactors shall have the forced guided contacts.

With OSSD in OFF state on the EDM input shall be present 24V.

With OSSD in ON state on the EDM input shall be present 0V.

The barrier checks the EDM input after the power on, and at every change state of the OSSDs.

The barrier checks the time of ON / OFF commutation, it shall be max 500 ms.

If the EDM is not utilized, shall be connected to OSSD 0 output.

Reset

START-E	Input for reset selection
START	Input for restart pushbutton

AUTOMATIC RESET

With the selection of the automatic reset, the OSSDs outputs follow the state of the barrier.

When the protected area is free, automatically the OSSDs go in ON state.

Take into consideration that in this case there is no the start interlock. If this function is necessary, verify that other means are present to stop the machine at the power on.

MANUAL RESET

One push button NO shall be activated to start or re-start the OSSD0 and OSSD1 after the interruption of the beams or when the ESPE is turned on at first time.

This pushbutton must be located outside the dangerous area, and shall not be possible to activate it from inside of the dangerous area. It shall be located where is possible to check the dangerous area. The manual reset has the function of start interlock.

This system shall be utilized when the barrier is employed for the protection of a dangerous passage.

The following table show the reset setup.

START- E	START	Function selected
0Vdc	24Vdc	AUTOMATIC RESET
24Vdc	NO / 24Vdc	MANUAL RESET

Muting

MUTING with two sensors.

The muting function generates a temporary suspension of the protective function of the barrier in order to ensure the normal passage of the material through the protected area. If the MUTING function is active, the interruption of the beams doesn't disable the OSSDs outputs.

The muting function is activated through the activation of two sensors within 2 sec of each other.

Any others conditions applied to the sensors don't activate the MUTING function.

During the MUTING the two sensors shall be always active. Disabling a muting sensor terminates the muting function.

A signalling MUTING lamp can be connected to MUTE-S output to indicate that the MUTING function is active.

If for any reason, the muting doesn't activate, the interruption of the beams will determine the block of the machine. In this case the cycle can be restarted using the **GUARD-OVERRIDE** command.

The GUARD-OVERRIDE function can be utilized only at the following conditions:

- the muting enable command is active, and
- mistake of sequence of muting sensors, and
- at least one beam of vertical barrier is interrupted, and
- the correct activation of the GUARD OVERRIDE commands.

The GUARD-OVERRIDE it is not performed if:

- the muting enable command is not active, or
- one command of GUARD OVERRIDE is OFF, or
- time out expired, or
- all mute inputs and the beams are free.

The command for the GUARD OVERRIDE is formed by a couple of contacts NO (i.e. key selector with spring return) that shall be activated simultaneously within 300 msec. If this don't happens the guard-override function will not be activated.

The opening of only one contact cause the stop function.

The time out is 3 minutes. After this time, the guard-override function is terminate.

The OVER indicator is ON if the guard-override function is active and vice versa.

The OVER indicator blinks if are past the 3 minutes of TIME OUT, or if the MUTING conditions have been restored (vertical beams are free and MUTING sensors are free) and the GUARD OVERRIDE command is still active.

MUTE-E	MUTING Enable input
---------------	----------------------------

Input for enable the MUTING function.

If connected to 24Vdc the MUTING function is enabled and the E-MUTE indicator is ON, otherwise if floating or connected to 0V, the MUTING function is not enabled and the E-MUTE indicator is OFF.

MUTE - 0	EXTERNAL MUTING - sensor 0 input
MUTE - 1	EXTERNAL MUTING - sensor 1 input
MUTE - 2	INTERNAL MUTING - sensor 2 input
MUTE - 3	INTERNAL MUTING - sensor 3 input
MUTE - 4	INTERNAL MUTING - sensor 4 input
MUTE - 5	INTERNAL MUTING - sensor 5 input

Inputs for external(0 and 1) and internal(from 2 to 5) muting sensors.

If they are connected to 24Vdc are active, and SENSE 0 / 1 indicators are ON if activated external muting, otherwise if are floating or are connected to 0V, are not active and SENSE 0 / 1 indicators are OFF.

GOVR-0	Guard Override 0 input
GOVR-1	Guard Override 1 input

Inputs for external guard override commands.

If they are connected to 24Vdc the GOVR-0 / 1 are active, and OVER indicator is ON, otherwise if are floating or are connected to 0V, the GOVR-0 / 1 aren't active and OVER indicator is OFF.

MUTE-S	Output MUTING Lamp
---------------	--------------------

Output for MUTING lamp.

The muting lamp is active (+24V) when the MUTING function is active and vice-versa.

MUTE-F	Muting phase, main beams interrupted
---------------	--------------------------------------

This output is active (+24V) only when the muting function is active and the beams of the “ Sensitive Height ” are interrupted and vice-versa.

For other details of muting function see pag. 32.

TIME- 0	Input 0 - configuration MUTING time
TIME- 1	Input 1 - configuration MUTING time

Input for the selection of the duration of MUTING. These inputs are only on the model of light curtain type G (G1, G2).

The configuration is set using two wires on the connector of the receiver and is stored when light curtain is ON.

Any configuration changes during normal operation will not be accepted until a subsequent cycle ON / OFF of the light curtain.

Selecting inputs, as shown in the table below, we can set the duration of the MUTING function.

MUTING SETTING TIME		
SENSE-1	SENSE-2	Maximum duration of the Muting
ON	ON	1 minute
OFF	ON	24 hour
ON	OFF	90 minutes
OFF	OFF	1 minute

If an error occurs on the connection of the TIME-0 and TIME-1 signals caused by broken cables, fault inside the light curtain, the maximum MUTING time will be set to the lowest value (1 minute).

KEEPER RECEIVER - EXTERNAL ARMS CONNECTION

The barriers of the series TPi3, TXi3, LPI3, LXi3 must be connected to external muting sensors provided by the customer, these versions allow maximum installation flexibility for non-standard applications.

The transmitter is provided with only M12 connector to power supply and input command TEST.

The receiver is provided with the standard connections + 1 or 2 cables with M12 5-pin female connectors to which the client will connect the muting sensors.

The sensors can be photoelectric sensors, proximity, capacitive, micro mechanics switches, with NO contacts or PNP outputs. To activate the muting function the sensors must provide 24VDC when are activated. Sensors and barrier must have the common GND.

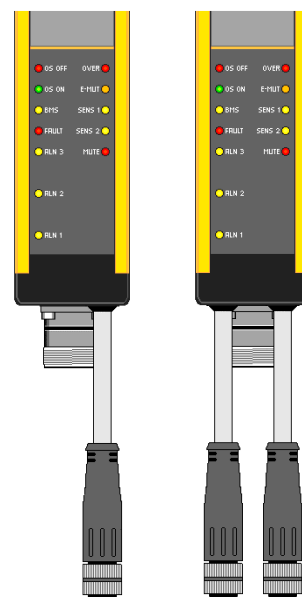

TXi3
LPI3
LXi3

TPi3

The following tables shows the connections for external MUTING sensors. Refer to page 34 for details of the identifier of the sensor and its location in the geometric configuration choice.

VERSION T AND L WITH CROSSED BEAMS – L WITH PARALLEL BEAMS

Ricevitore		KP- ... -				
N pin	Colore filo	Funzione	Descrizione	Tipo	Livelli	
M12 4 poli						
1	Brown	+24V	Positive power supply	IN	+24Vdc +/- 10% 0,5A	
2	White	MUTE 1	MUTING 1 input sensor	IN	0 - 24 Vdc 10mA	
3	Blue	GND	0V power supply	IN	0V	
4	Black	MUTE 2	MUTING 2 input sensor	IN	0 - 24 Vdc 10mA	
5	Grey	PE	Ground	-	-	

VERSION - T WITH PARALLEL BEAMS

Ricevitore		KP- ... -				
N pin	Colore filo	Funzione	Descrizione	Tipo	Livelli	
M12 5 poli destro						
1	Brown	+24V	Positive power supply	IN	+24Vdc +/- 10% 0,5A	
2	White	MUTE 1	MUTING 1 input sensor	IN	0 - 24 Vdc 10mA	
3	Blue	GND	0V power supply	IN	0V	
4	Black	MUTE 2	MUTING 2 input sensor	IN	0 - 24 Vdc 10mA	
5	Grey	PE	Ground	-	-	
M12 5 poli sinistro						
1	Brown	+24V	Positive power supply	IN	+24Vdc +/- 10% 0,5A	
2	White	MUTE 3	MUTING 3 input sensor	IN	0 - 24 Vdc 10mA	
3	Blue	GND	0V power supply	IN	0V	
4	Black	MUTE 4	MUTING 4 input sensor	IN	0 - 24 Vdc 10mA	
5	Grey	PE	Ground	-	-	

INDICATIONS and DIAGNOSTIC

Below are the main functions related to each indicator and its status.

TRANSMITTER

POWER-TEST	YELLOW - Power On & Test
-------------------	--------------------------

If the indicator is ON, the power supply is connected correctly.

If the indicator blinks, the TEST function is active.

FAULT	RED - Fault
--------------	-------------

If the indicator is ON, the light curtain is stopped due to an internal failure.
In this case contact the technical support.

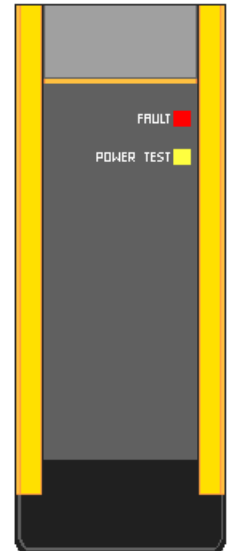

RECEIVER

OS OFF	RED - State of OSSD0 e OSSD1
---------------	------------------------------

The OSSD0 and OSSD1 outputs are in OFF state.

OS ON	GREEN - State of static OSSD0 e OSSD1
--------------	---------------------------------------

The OSSD0 and OSSD1 outputs are in ON state.

BMS	YELLOW - Wait external reset
------------	------------------------------

If all beams of the sensitive zone are aligned and the manual RESTART is selected, the indicator is ON. After pressed and released the restart button, the indicator is OFF.

FAULT	RED - Fault
--------------	-------------

If the indicator is ON, the light curtain is stopped due to an internal failure.
In this case contact the technical support.

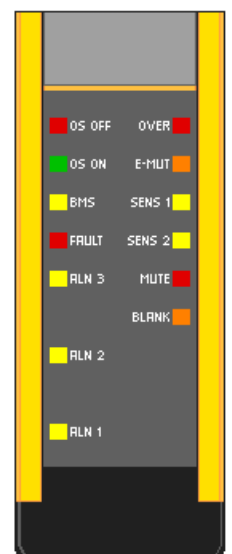

AL1	YELLOW - BARGRAPH Led 1
AL2	YELLOW - BARGRAPH Led 2
AL3	YELLOW - BARGRAPH Led 3

The three LEDs provide indications on the beams alignment. This simplifies the alignment of the light curtain, particularly in case of difficult installations, for example with the use with mirrors or on long range. To each indicator is associated a percentage of beams aligned. The indications given are summarized in the following table.

AL1	AL2	AL3	DESCRIZIONE
OFF	OFF	OFF	No beam is alignment or the first beam is interrupted
BLINK	OFF	OFF	The number of the beams is less than 1/3 of total beams
ON	BLINK	OFF	The number of rays is aligned between 1/3 and 2/3
ON	ON	BLINK	The number of rays is aligned between 1/3 and up to maximum
ON	ON	ON	All beam are alignment

The blink period is 1 second.

When the OSSDs go from OFF to ON state, the alignment indicators will turn OFF.

OVER	RED - GUARD OVERRIDE function
-------------	-------------------------------

If the GUARD OVERRIDE function is active the indicator is ON, and vice-versa. If there is an error on the function activation, the indicator blinks (see pag 25).

E-MUTE	ORANGE - MUTING Function enabled
---------------	----------------------------------

If the MUTING function is enabled the indicator is ON, and vice-versa.

SENSE-1	YELLOW - External Muting Sensor 1
----------------	-----------------------------------

If the MUTING sensor 1 is active the indicator is ON, and vice-versa. This indicator , in the G model indicate the duration of MUTING.

SENSE-2	YELLOW – External Muting Sensor 2
----------------	-----------------------------------

If the MUTING sensor 2 is active the indicator is ON, and vice-versa. This indicator , in the G model indicate the duration of MUTING.

MUTE	Red – gives the function of MUTING
-------------	------------------------------------

If the MUTING function is active the indicator is ON, and vice-versa.

INDICATORS MUTING TIME		
SENSE-1	SENSE-2	Maximum duration of the Muting
ON	ON	1 minute
OFF	ON	24 hour
ON	OFF	90 minutes
OFF	OFF	1 minute

BLANK	Not used
--------------	----------

Further indication to find the faults.

MANUAL and AUTOMATIC RESTART

If an error occurs in the reset setting, the FAULT indicator is ON and AL1 indicator blinks. The light curtain is locked.

Turn OFF the light curtain, check the reset settings and then turn ON the barrier.

The principal causes can be :

- restart wires not connected properly;
- push button of manual reset is NC instead of NO;
- push button of manual reset pressed during the turn on of the barrier.

OSSD 0 / OSSD 1

If an error occurs on the OSSD output, the FAULT indicator is ON and AL2 indicator blinks. The light curtain is locked.

Turn OFF the barrier, check the OSSD output connections and then turn ON the power supply.

The principal causes can be :

- short circuit between OSSD;
- OSSD connected to +24V or 0V;
- capacitive load beyond the limit, excessive cable length ;
- wrong connection of the outputs;
- internal fault.

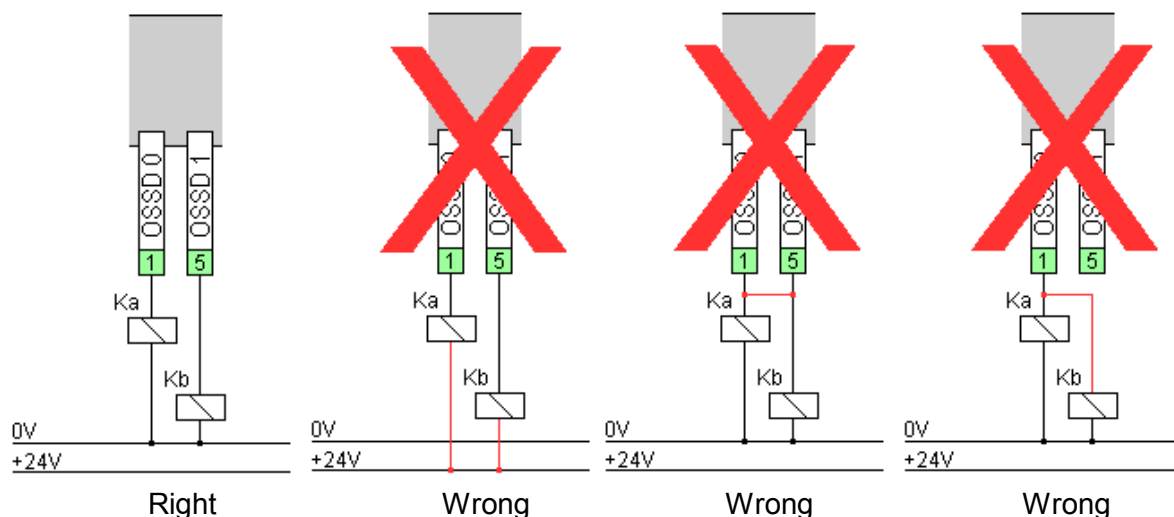

EDM

If an error occurs on the EDM function, the FAULT indicator is ON and AL3 indicator blinks. The light curtain is locked.

Turn OFF the barrier, check the EDM connections and then turn ON the power supply.

The principal causes can be :

- wire not connected;
- wire connected to fixed voltage(+24V o 0V);
- contact of external device open when the OSSD are active;
- voltage to external device not present or not correct ;
- external contactor defective.

In Automatic reset every 15s the barrier test the EDM input, if the safety conditions are met the barrier will be activated.

In Manual reset If the safety conditions are met the BMS indicator is ON.

Press and release the RESTART push button to activate the barrier.

GUARD OVERRIDE

If an error occurs in the GUARD OVERRIDE function, the FAULT indicator is ON and the OVER indicator blinks. The light curtain remain locked. Turn OFF the barrier, check the GUARD OVERRIDE connections and then turn ON the power supply.

The principal causes can be :

- one or two contacts are normally closed instead of normally open ;
- break of one contact ;
- end of the GUARD OVERRIDE time out ;
- non simultaneous closing of contacts in the maximum expected time of 300 ms.

SERVICE AND TEST

Attention

Each repair operation should be performed only by GREIN authorized technicians.

Putting into service and tests at regular intervals

The installer that put the equipment into service shall have all necessary information about the machine or the plant, and the installed ESPE KEEPER.

The testing shall cover the correct interaction of the ESPE and the control system of the power-operated working equipment, the safe state and the construction in compliance with the equipment-specific safety rules. The test-relevant information provided by the machine or plant manufacturer (e.g. a press manufacturer) shall always be observed when testing.

A distinction is made between the following types of test:

Testing prior to put a device into service for the first time and after modifications (approval tests)

An authorized, qualified person should test the ESPE prior to its being put into service for the first time, and after its - or its components / units involved in the safety function - having been modified.

All changes of the circuit/switching, the control system, the ESPE configuration and the involved components/units affecting the safety function are considered a modification.

Those tests are to determine that the power-operated working equipment (e.g. the press) fulfils the requirements when the ESPE is employed, and that the correct operation of the components/units involved in the safety function is ensured for the interaction with the ESPE. Furthermore, type of use and installation of the ESPE shall be tested.

Periodical tests

Periodical tests serve the purpose of systematically detecting and removing safety-relevant deficiencies (e.g. in the event of modification or manipulation) of the protective equipment of the machine or facility which occur after the machine/facility having been put into service. Type, scope and time intervals to be followed are listed in clause "**SETTING UP AND TEST**" of the ESPE's instructions for use, and shall be determined and specified for each individual working equipment. All tests, it shall comply with national regulations working type C. The test results shall be recorded and writing in a report which is to be signed by the inspector. The report shall be kept at the installation site of the machine or facility, respectively.

Maintenance

Periodically clean the front of the barriers using a soft damp cloth.

Do not use solvents or abrasives. For particularly hostile environments where is required a very intense cleaning you can request the glass protection that allows the use of more aggressive solvents.

SETTING UP AND TEST

FINAL CHECK BEFORE STARTING

Before connecting the curtain to the power supply, ensure that:

- the value of power supply is 24V;
- connection cables of emitter and receiver to machine are correct.

When the barrier is aligned, if AUTOMATIC RESTART is set, the OS ON indicator will turn ON and the 24Vdc is present on OSSDs outputs. Otherwise, if the MANUAL RESTART is set, the BMS indicator is ON and OS ON is OFF, then press and release the START button to activate the barrier(24Vdc is present on OSSDs outputs, BMS is OFF and OS ON is ON).

Performing the periodical test follow the verifications listed below:

Hint: To ensure major safety, perform these tests in manual reset.

Daily testing of the protective device by authorized personnel.

By the operator, daily or prior to each work session by means of complete coverage of every beam of light.

Move the test rod slowly through the length of the protective field at three different points:

- 1) Protective field limits / protective field markings close to sender (access opening);
- 2) Protective field limits / protective field markings close to receiver;
- 3) Protective field limits in middle between transmitter and receiver.

During the test, the BMS indicator must be turned OFF. If during this test the BMS indicator is lights up, it is necessary to verify the mechanical installation in accordance with the minimum distance to avoid the reflecting signal as reported in page 9.

Check for damage to the protective device, in particular the mounting, electrical connection.

Check for wear or damage to the housing, front screen or electrical connection cable.

Check that people or body parts can only access the danger zone through the protective field.

If one or more errors occur during the test, the machine must be shut down.

Now the light curtain is ready for working and you can select the automatic or manual reset as desired.

LIST OF THE MODELS AND THE CHARACTERISTICS

The images describes the main parameters considered in the selection of light curtain and in the following pages shows the complete list of barriers "KEEPER" series.

Total height. Total height. To estimate the total height of the barrier check the column H (barrier height) in table below and add the connector height how show in the figure below.

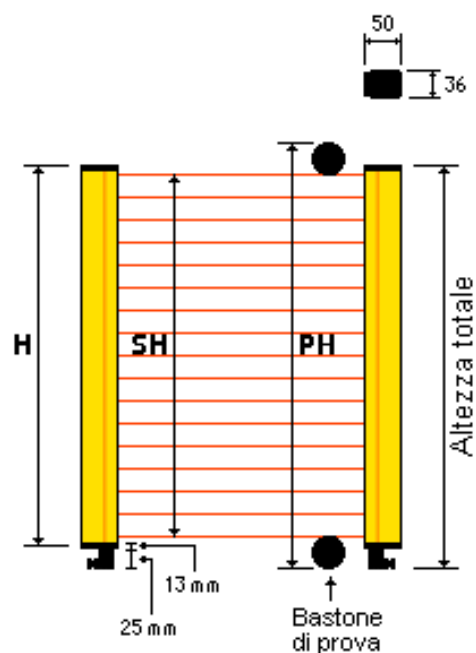

Minimum dimensions for the connection

It is necessary to provide a minimum space for the connector, refer to figure below.

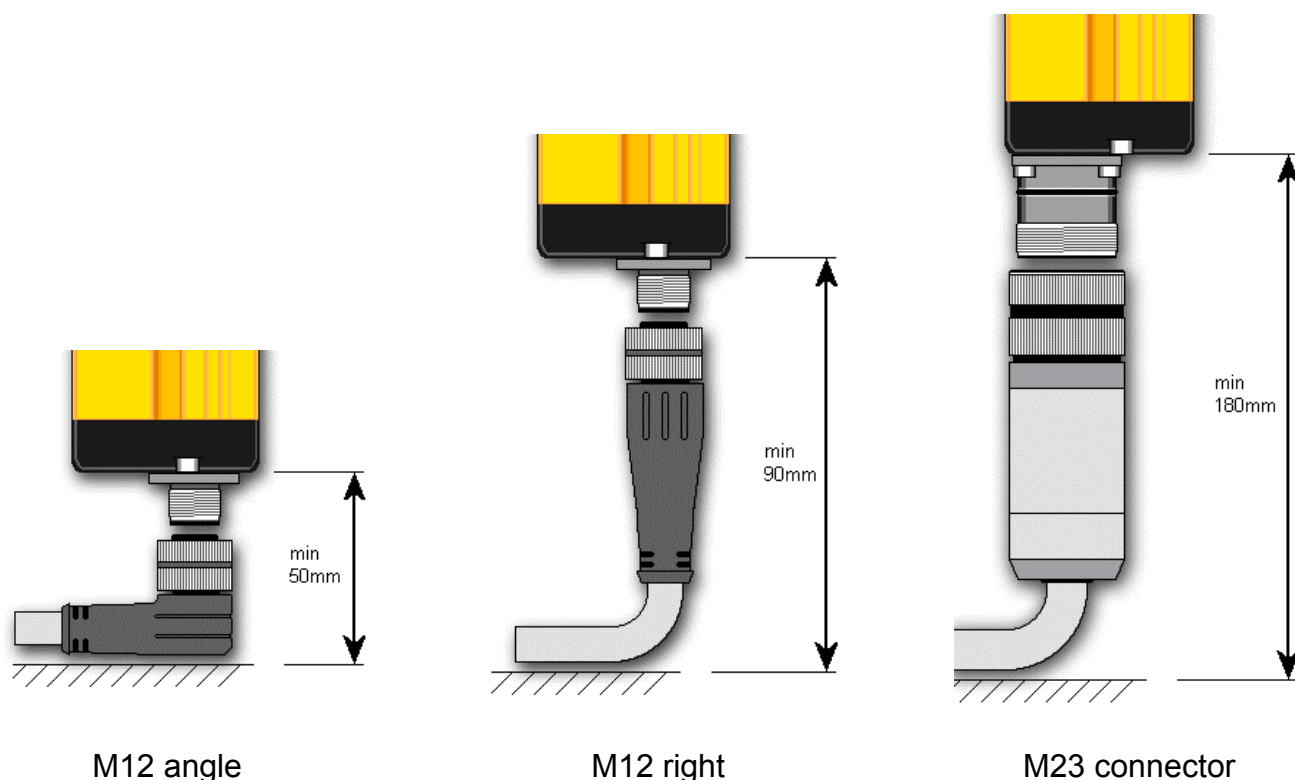

Special size. If the standard barriers don't satisfy the customer application, our technical office will evaluate the possibility to produce a custom model.

Optics

Optica	Risoluzione	Portata min	Portata max X	Portata max P	Portata max I
-- A	14 mm	0m	2.5 m	5 m	6 m
-- B	30 mm	0m	2.5 m	5 m	15 m
-- C	55 mm	0m	2.5 m	5 m	15 m
-- D	175mm	0m	2.5 m	5 m	15 m
-- E	320mm	0m	2.5 m	5 m	15 m

Resolution 14mm Range 0 - 6m Optical Code "A"									
Model	N° of beams	Protected Height PH (mm)	Sensitive Height SH (mm)	Barrier Height H (mm)	Weight (Tx+RX) (Kg)	Response Time (ms)	Mtff (years)	PL	
KP - x - 240 A - y	24	254	234	326	1,2	6	100	e	
KP - x - 360 A - y	36	374	354	446	1,6	11	100	e	
KP - x - 480 A - y	48	494	474	566	2,0	11	100	e	
KP - x - 600 A - y	60	614	594	686	2,4	11	100	e	
KP - x - 700 A - y	72	734	714	806	2,8	16	84,06	e	
KP - x - 850 A - y	84	854	834	926	3,2	16	76,09	e	
KP - x - 950 A - y	96	974	954	1046	3,6	16	69,51	e	
KP - x - 1100 A - y	108	1094	1074	1166	4,0	16	63,97	e	

Resolution 30mm Range 0,5 - 15m Optical code "B"									
Model	N° of beams	Protected Height PH (mm)	Sensitive Height SH (mm)	Barrier Height H (mm)	Weight (Tx+RX) (Kg)	Response Time (ms)	Mtff (years)	PL	
KP - x - 300 B - y	12	318	270	368	1,2	6	100	e	
KP - x - 450 B - y	18	462	414	512	1,6	6	100	e	
KP - x - 600 B - y	24	606	558	656	2,0	6	100	e	
KP - x - 750 B - y	30	750	702	800	2,4	11	100	e	
KP - x - 900 B - y	36	894	846	944	2,8	11	100	e	
KP - x - 1050 B - y	42	1038	990	1088	3,2	11	100	e	
KP - x - 1200 B - y	48	1182	1134	1232	3,6	11	100	e	
KP - x - 1350 B - y	54	1326	1278	1376	4,0	11	100	e	
KP - x - 1500 B - y	60	1470	1422	1520	4,4	11	100	e	
KP - x - 1650 B - y	66	1614	1566	1664	4,8	11	100	e	
KP - x - 1800 B - y	72	1758	1710	1808	5,2	16	100	e	
KP - x - 1950 B - y	78	1902	1854	1952	5,6	16	100	e	
KP - x - 2100 B - y	84	2046	1998	2096	6,0	16	100	e	
KP - x - 2200 B - y	90	2190	2142	2240	6,4	16	100	e	
KP - x - 2300 B - y	96	2334	2286	2384	6,8	16	100	e	
KP - x - 2450 B - y	102	2478	2430	2528	7,2	16	100	e	
KP - x - 2650 B - y	108	2622	2574	2672	7,6	16	99,18	e	

Resolution 55mm Range 0,5 - 15m Optical code "C"								
Model	N° of beams	Protected Height PH (mm)	Sensitive Height SH (mm)	Barrier Height H (mm)	Weight (Tx+RX) (Kg)	Response Time (ms)	Mtff (years)	PL
KP - x - 300 C - y	6	344	246	0	0,1	6	100	e
KP - x - 450 C - y	9	488	390	0	0,1	6	100	e
KP - x - 600 C - y	12	632	534	0	0,1	6	100	e
KP - x - 750 C - y	15	776	678	0	0,1	6	100	e
KP - x - 900 C - y	18	920	822	0	0,1	6	100	e
KP - x - 1050 C - y	21	1064	966	0	0,1	6	100	e
KP - x - 1200 C - y	24	1208	1110	0	0,1	6	100	e
KP - x - 1350 C - y	27	1352	1254	0	0,1	11	100	e
KP - x - 1500 C - y	30	1496	1398	0	0,1	11	100	e
KP - x - 1650 C - y	33	1640	1542	0	0,1	11	100	e
KP - x - 1800 C - y	36	1784	1686	0	0,1	11	100	e
KP - x - 1950 C - y	39	1928	1830	0	0,1	11	100	e
KP - x - 2100 C - y	42	2072	1974	0	0,1	11	100	e
KP - x - 2200 C - y	45	2216	2118	0	0,1	11	100	e
KP - x - 2300 C - y	48	2360	2262	0	0,1	11	100	e
KP - x - 2450 C - y	51	2504	2406	0	0,1	11	100	e
KP - x - 2650 C - y	54	2648	2550	0	0,1	11	100	e
KP - x - 2750 C - y	57	2792	2694	0	0,1	11	100	e
KP - x - 2900 C - y	60	2936	2838	0	0,1	11	100	e
KP - x - 3000 C - y	63	3080	2982	0	0,1	11	100	e

Resolution 175mm Range 0,5 - 15m Optical code "D"								
Model	N° of beams	Sensitive Height SH (mm)	Barrier Height H (mm)	Weight (Tx+RX) (Kg)	Response Time (ms)	Mtff (years)	PL	
KP - x - 400 D - y	4	414	0	0,1	6	100	e	
KP - x - 700 D - y	6	702	0	0,1	6	100	e	
KP - x - 1000 D - y	8	990	0	0,1	6	100	e	
KP - x - 1300 D - y	10	1278	0	0,1	6	100	e	
KP - x - 1600 D - y	12	1566	0	0,1	6	100	e	
KP - x - 1900 D - y	14	1854	0	0,1	6	100	e	
KP - x - 2100 D - y	16	2142	0	0,1	6	100	e	
KP - x - 2400 D - y	18	2430	0	0,1	6	100	e	
KP - x - 2700 D - y	20	2718	0	0,1	6	100	e	
KP - x - 3000 D - y	22	3006	0	0,1	6	100	e	

Resolution 320mm Range 0,5 - 15m Optical code "E"							
Model	N° of beams	Sensitive Height SH (mm)	Barrier Height H (mm)	Weight (Tx+RX) (Kg)	Response Time (ms)	Mtff (years)	PL
KP - x - 600 E - y	4	558	0	0,1	6	100	e
KP - x - 1000 E - y	6	990	0	0,1	6	100	e
KP - x - 1500 E - y	8	1422	0	0,1	6	100	e
KP - x - 1900 E - y	10	1854	0	0,1	6	100	e
KP - x - 2200 E - y	12	2286	0	0,1	6	100	e
KP - x - 2700 E - y	14	2718	0	0,1	6	100	e

BARRIER CODE

<table border="1"> <tr> <td>Kp - e</td> <td>1000</td> <td>E</td> <td>LFX1</td> </tr> </table>				Kp - e	1000	E	LFX1
Kp - e	1000	E	LFX1				
Model							
Sensitive height							
Optic Code							
Type of Muting							

EXTERNAL MUTING DETAILS

Before to use the muting function, should be evaluated :

- a. the application;
- b. the installation of the two sensors;
- c. the risk of the machinery or the plant.

In order to use the muting function, thus the knowledge and observance of the machinery / equipment-specific standards and the relevant standards or guidelines for machine safety / protective devices.

The following overview, which does not claim to be exhaustive, gives some of the major standards:

EN 61496-1	Safety of machinery - Electro-sensitive protective equipment
EN 60947-5-3	Low-voltage switchgear and controlgear
EN ISO 13855	Safety of machinery - Positioning of protective equipment
IEC/TS 62046:2008	Safety of machinery - Application of protective equipment to detect the presence of persons

!! Warning !!

SAFETY INSTRUCTION

!! Warning !!

Failure to observe the following instructions may lead to most severe injuries and death.

- Observe the above-mentioned standards as regards configuration, installation and operation of muting systems.
- Take measures to exclude common mode failures.
- Take measures to exclude failures by cross circuits.
- Take measures to prevent the muting function from being tripped by persons.
- Please note that a muting function shall not be initiated until the preceding muting function has been terminated.
- Take measures to safeguard maintenance gates to the danger zones in compliance with the necessary safety level.

The muting function integrated in the KEEPER is appropriate for applications where the muting sensors used to initiate the muting function are the same as those used to terminate the muting function.

Muting sensors location and positioning:

The muting sensors shall be located such that the user is not able to manipulate / defeat the muting sensors in order to activate the muting function. The above-mentioned standards and safety instructions shall be observed.

This means e.g. for safeguarding the access with use infrared emitter-receiver type as sensors:

- the beams of the muting sensors shall always meet in the danger zone.
- the muting sensors shall be positioned / located such that the light grid is interrupted before it is possible to reach the beam intersection point.

Type and connection of the sensors

The sensors can be of every type (also no safety sensor) because the internal circuit of the barrier provide the control of the same and to block on the case of damage .

These components can be choice between proximity, mechanical micro , light curtains, ect as specify on the standard machinery. When activate, the muting sensor must supply 24Vdc.

To avoid common mode failures the conductors must be of type armed against the mechanical crushing and screened electrically. Their installation must happen on two separate runs for avoid that a possible cause could damage both the connections with a short circuit or with the cut of the conductors.

Sequence function of muting, MUTE0 and MUTE1 inut sensors

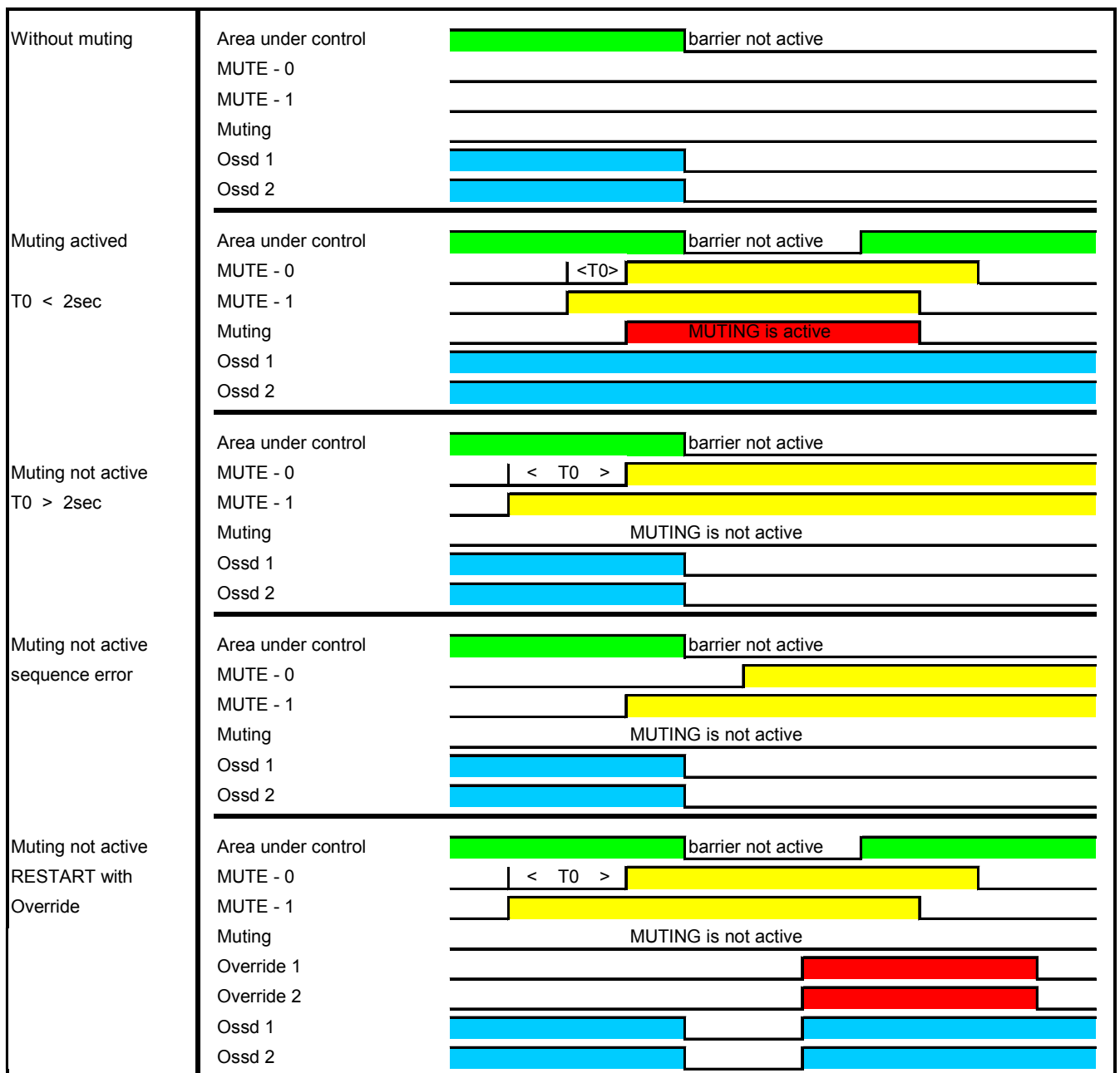

DETAILS INTERNAL MUTING FUNCTION

The models T and L can support the internal and external sensors for the realization of the MUTING beams and the resulting bounding the hazardous area.

The external sensors that can be applied are proximity switch, capacitive, mechanical, etc.

The output signal from these sensors must assume a voltage level of + 24V when the sensor is active.

In the case of optical sensors, the receiver output signal assume + 24V when the infrared beam is interrupted(type DARK ON).

In the following figures there are some types of applications of internal and external sensors with use of optical type sensors. For all models, except G model, the maximum duration of the MUTING function is fixed at 24 hours. For G model, the duration of the muting time is selectable with TIME-0 and TIME-1 signals(more informatio on page 22).

L MODEL WITH CROSSED BEAMS

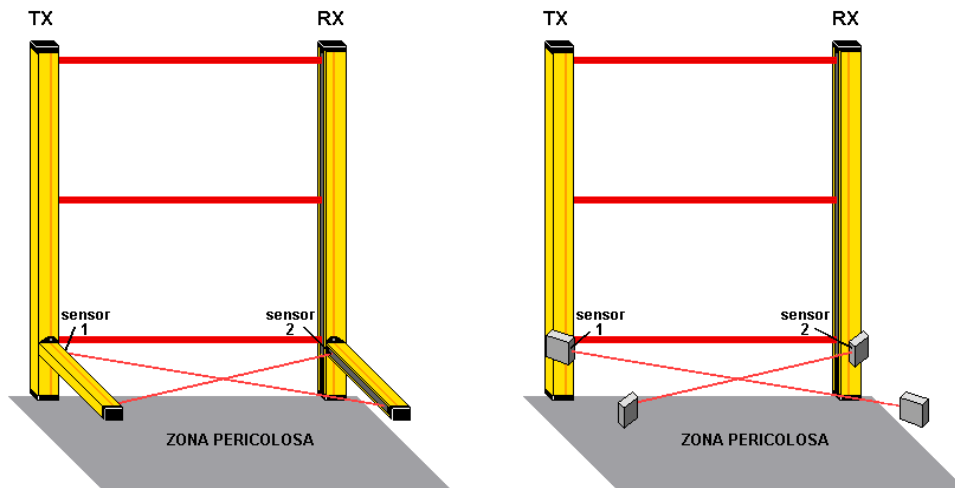

This model is unidirectional and is used only for one-way openings with pallet exit. The sensors form a cross between the rays of MUTING. The MUTING arms must be positioned within the dangerous zone. The interruption within 2 seconds of the 1 and 2 sensor, will activate the MUTING function.

The barrier will exclude the safety protection(vertical beams)within 100ms after the activation of the last sensor. When one of the two sensors is deactivated (not interrupted) the MUTING function finishes. The light curtain restore the dasety protection within 2 sec from the deactivated of the first sensor. In this time the pallet must leave the danger zone. If the working material is still inside in the danger zone, the OSSD outputs change state from ON to OFF state, in this case, the OVERRIDE function can be used to restore the system.

In this application, the minimum distance between two consecutive pallets must be roughly less than 100 mm, or as a minimum:

distance between pallet [mm] = $V + 260$ where V = speed of transport in mm / sec.

L MODEL WITH CROSSED BEAMS - ACTIVATION SEQUENCE

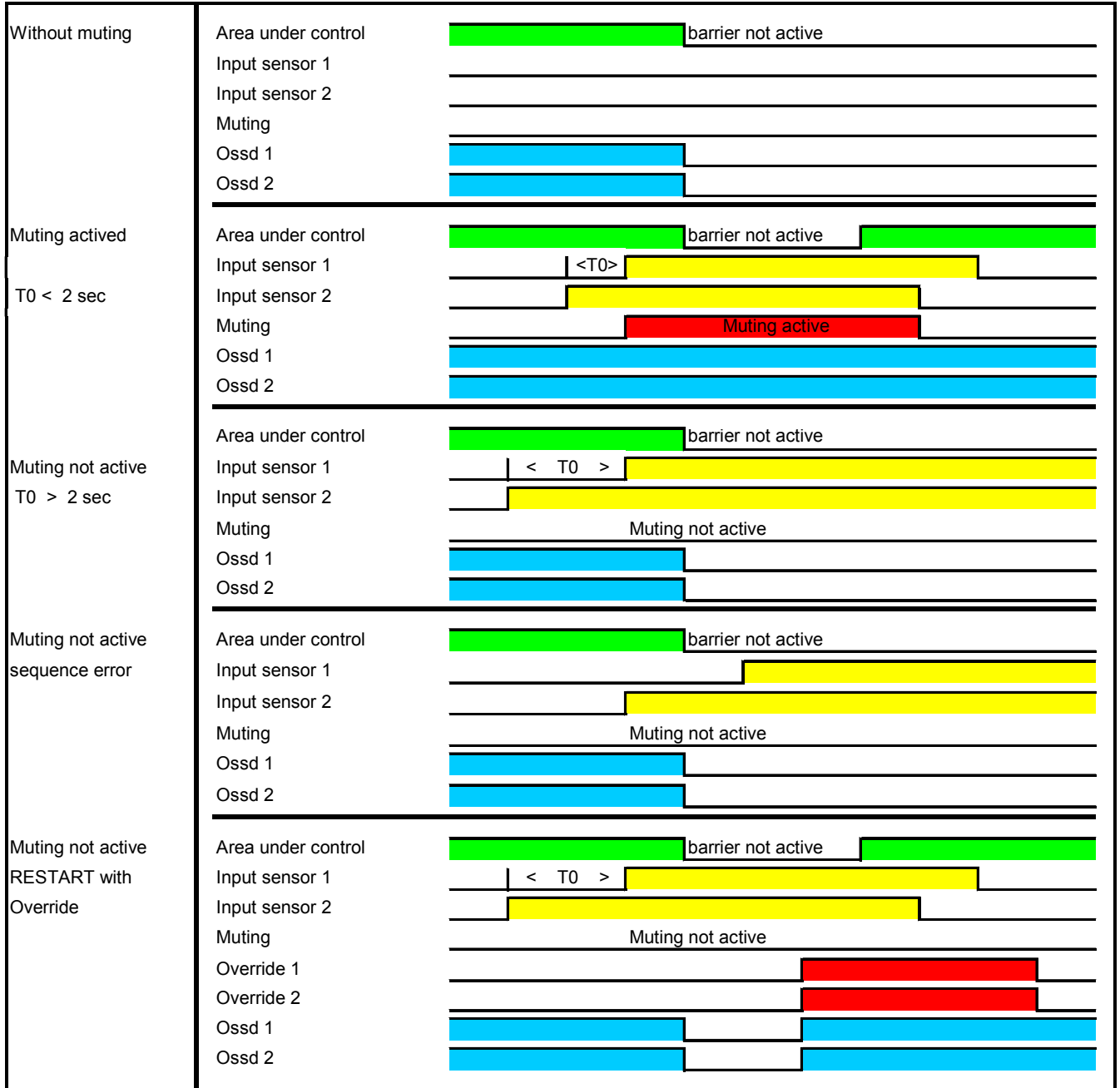

T MODEL WITH CROSSED BEAMS

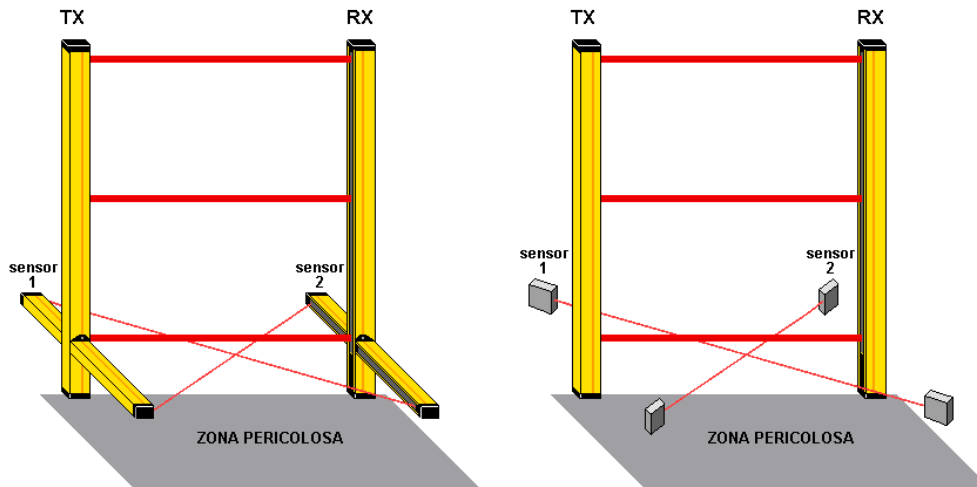

This model is bidirectional and is used for two-way openings with pallet entrance/exit. The sensors form a cross between the rays of MUTING. The MUTING arms must be positioned within the dangerous zone. The interruption within 2 seconds of the 1 and 2 sensor, will activate the MUTING function. The barrier will exclude the safety protection(vertical beams)within 100ms after the activation of the last sensor. When one of the two sensors is deactivated (not interrupted) the MUTING function finishes. The light curtain restore the safety protection within 2 sec from the deactivated of the first sensor. In this time the pallet must leave the danger zone. If the working material is still inside in the danger zone, the OSSD outputs change state from ON to OFF state, in this case, the OVERRIDE function can be used to restore the system.

In this application, the minimum distance between two consecutive pallets must be roughly less than 100 mm, or as a minimum 350mm.

T MODEL WITH CROSSED BEAMS - ACTIVATION SEQUENCE

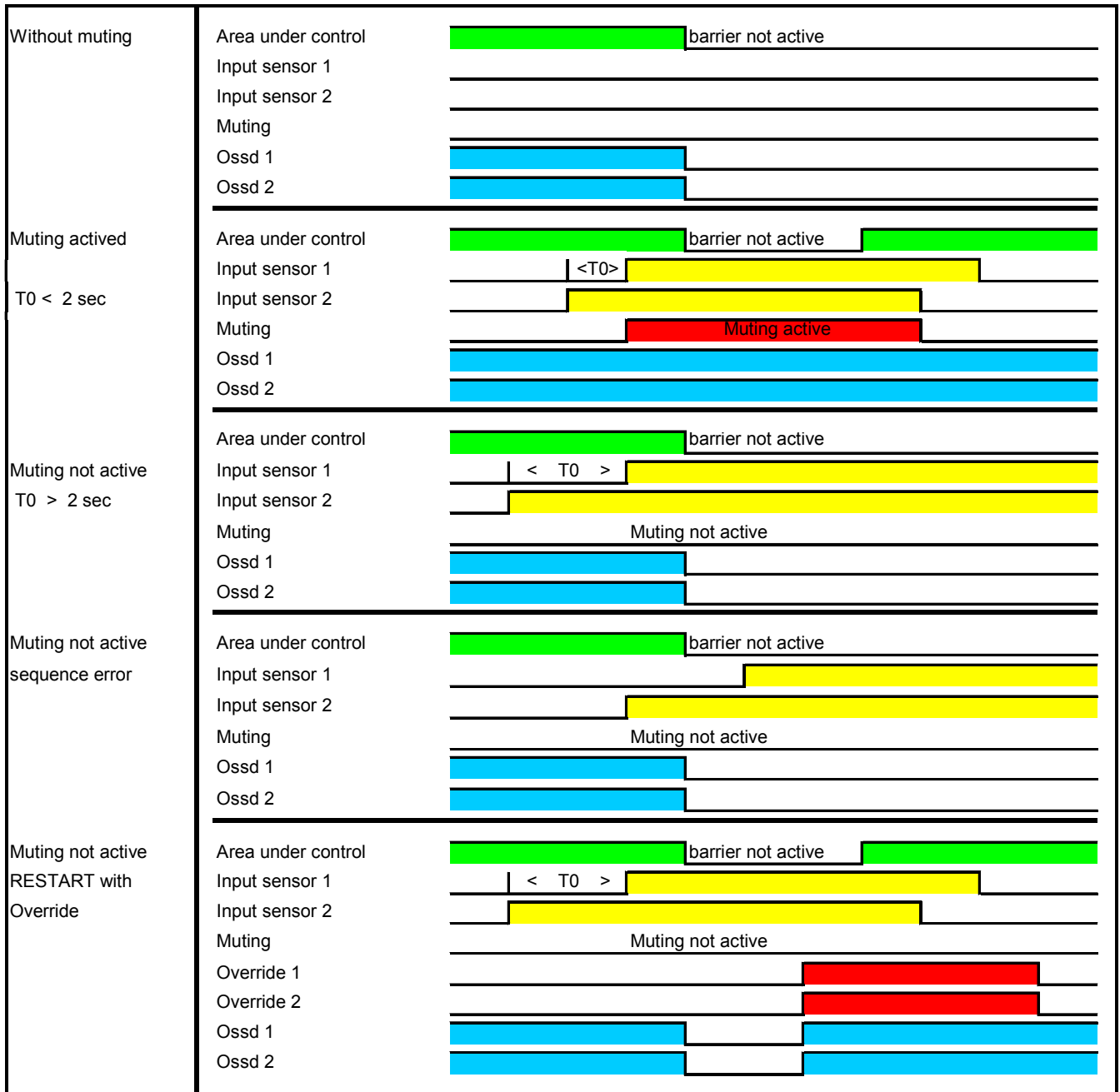

L MODEL WITH PARALLEL MUTING BEAMS

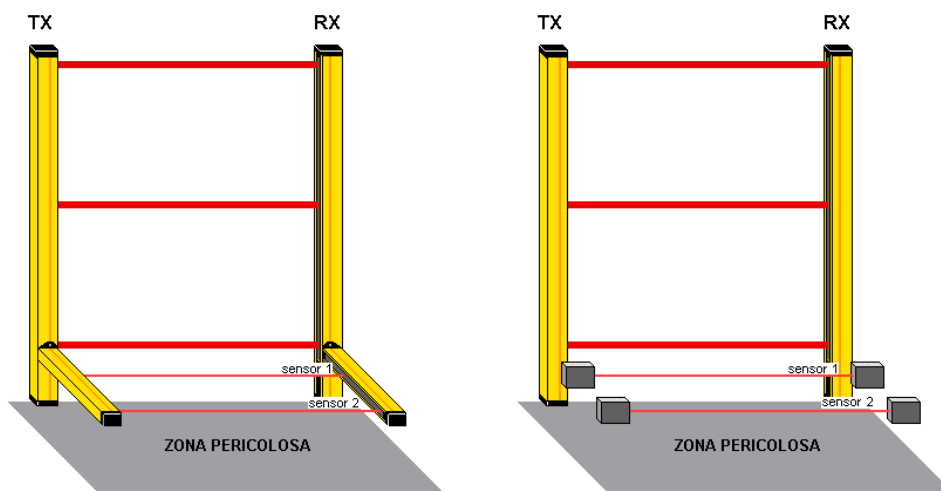

This barrier model is bidirectional and is used for the protection of input and output gates in palletizing machines. The sensors form two parallel beams. The MUTING arms must be positioned within the dangerous zone. The MUTING function is active when occurs the interruption of sensor 1 and then the sensor 2. The interruption time of the muting beams must be between 0.3 to 5 seconds. The disabling of the MUTING function occurs with the sensor 1 is deactivated and then the sensor 2 is deactivated. When the sensor 2 is deactivated, there are still 5 seconds to free the dangerous area by the presence of the material. After this time, if the material is still within the dangerous zone, the OSSD outputs change state from ON to OFF. In this case, the OVERRIDE function can be used to restore the system.

In this application, the minimum distance between two consecutive pallets must be a minimum:

$$\text{distance between pallet [mm]} = V + 260 \text{ where } V = \text{speed of transport in mm / sec}$$

In case of use of external sensors, to avoid optical interference between the adjacent photocells is advisable to use models with narrow emission angle, and alternate transmitters and receivers as shown in this figure.

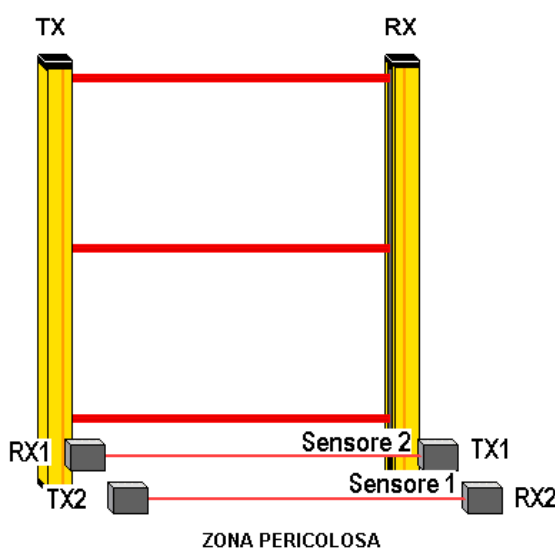

L MODEL WITH PARALLEL MUTING BEAMS - ACTIVATION SEQUENCE

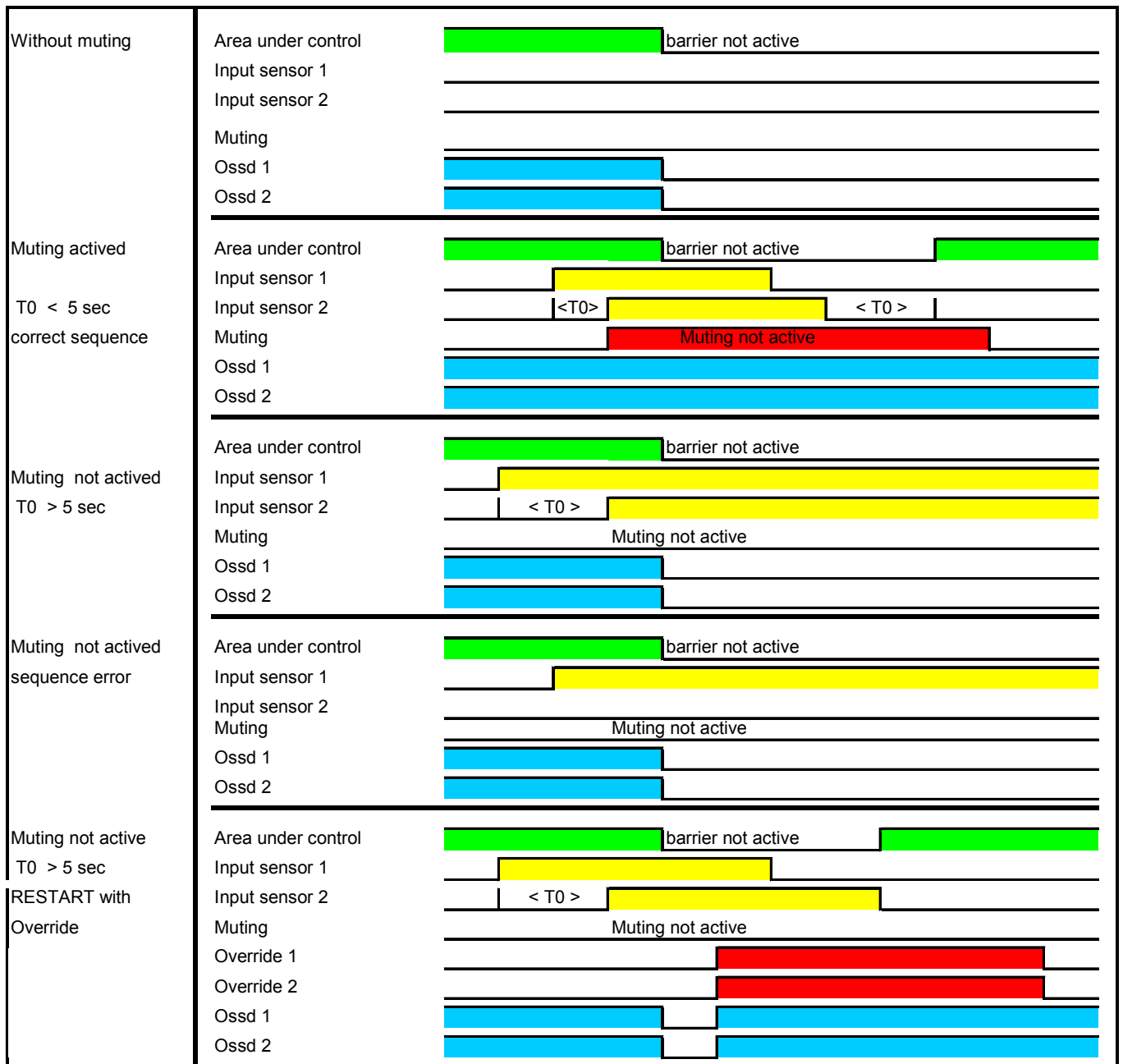

T MODEL WITH PARALLEL MUTING BEAMS

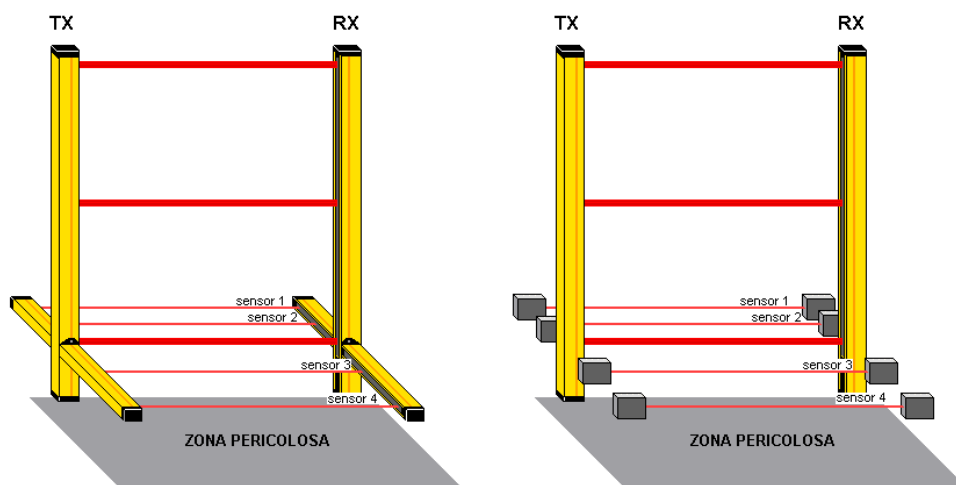

This barrier model is bidirectional and is used for the protection of input and output gates in palletizing machines. Inside, to each arm, there is a pair of sensors for forming a total of four parallel beams. The activation of the MUTING function is sequential. The interruption of the sensors 1, 2, 3, 4 and vice versa 4, 3, 2 and 1 active the muting function. The interruption of the sensors 1 and 2 (or 4 and 3) must be between 0.3 and 5 seconds. The deactivation of the sensors 1, 2, 3, 4 and vice versa 4, 3, 2 and 1 disables the muting function.

In this application, the minimum distance between two consecutive pallets must be greater than 510 mm.

In case of using external sensors, to avoid optical interference between adjacent photocells is advisable to use models with narrow beam angle, and alternate transmitters and receivers.

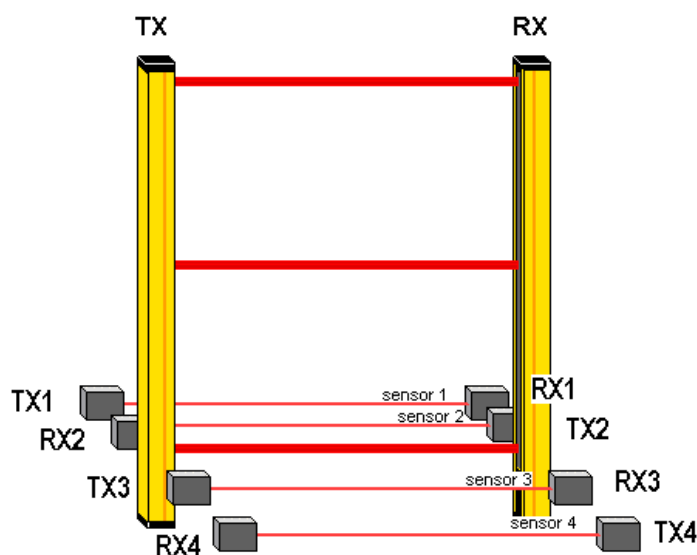

T MODEL WITH PARALLEL MUTING BEAMS - ACTIVATION SEQUENCE

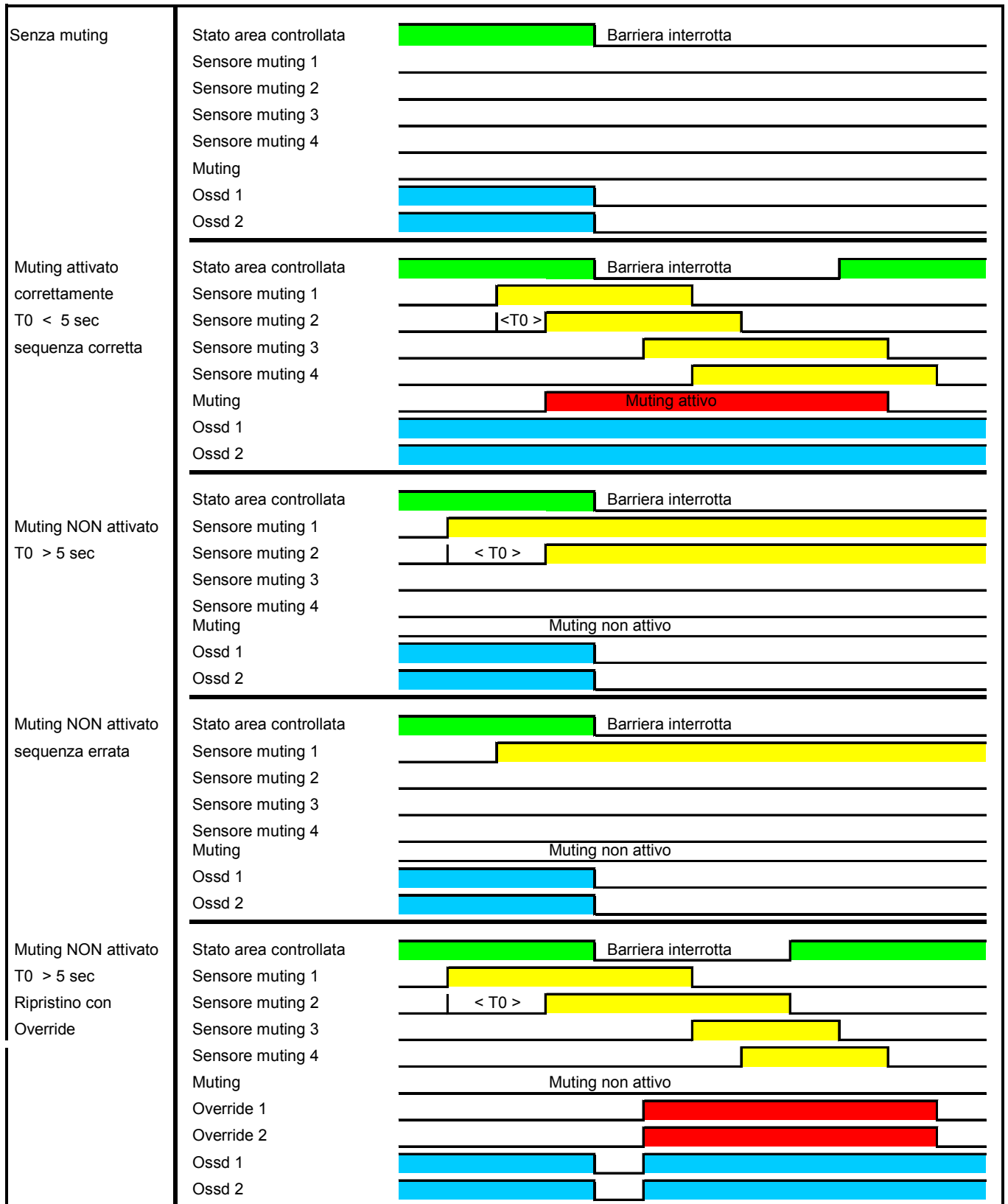

MUTING COMBINATION

The KEEPER light curtain can activate and maintain the MUTING function with external muting (MUTE0 and MUTE1 input sensors) , internal muting(L or T configurations) or by a combination of both.

The activation conditions and timings are identical to those analyzed for the individual types of MUTING(internal and external).

PLACEMENT AND ADJUSTMENT OF MUTING ARMS

In order to avoid problems of discontinuous darkening of the "MUTING" sensors on the part of the material in transit, the arms are equipped with horizontal and vertical adjustment. Appropriate adjustments in height and angle allow to vary the intensity of the signal received by the arms of the receiver.

To make the adjustment:

- loosen the screws holding the arm;
- operate on the arms to make the necessary adjustments;
- retighten screws for locking the arm.

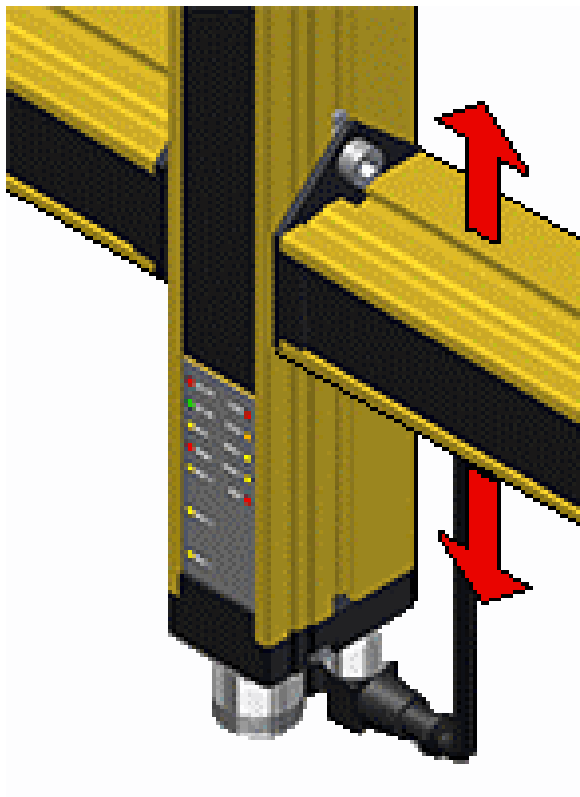

ACCESSORIES

BRACKETS

KIT brackets type "STVB"

Supplied as standard with the barrier.

It is the more complete bracket: it is composed from two units (VB1 and VB2) that allow the rotation of the light curtain on the 3 axes in order to regulate the alignment of TX or RX unit.

They include :

- 4 brackets VB1
- 4 brackets VB2
- 4 washers $\varnothing 6$
- 4 screws M 6X8
- 8 screws M 5X8

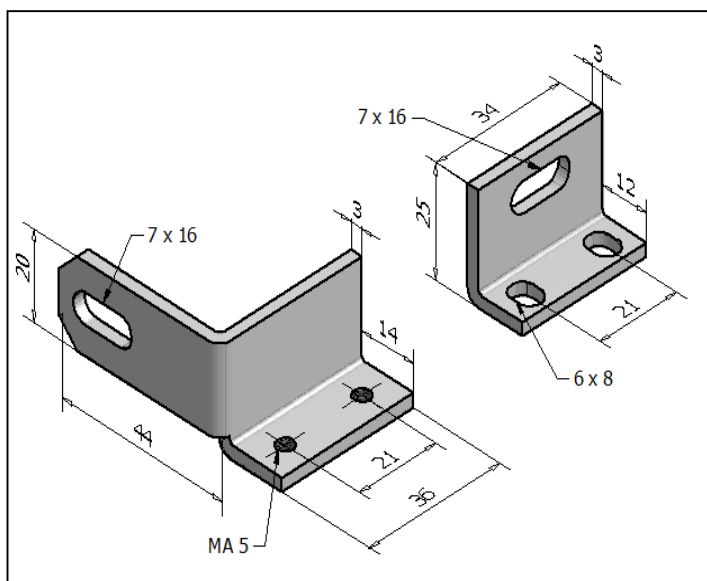

Brackets type VB1 / VB2

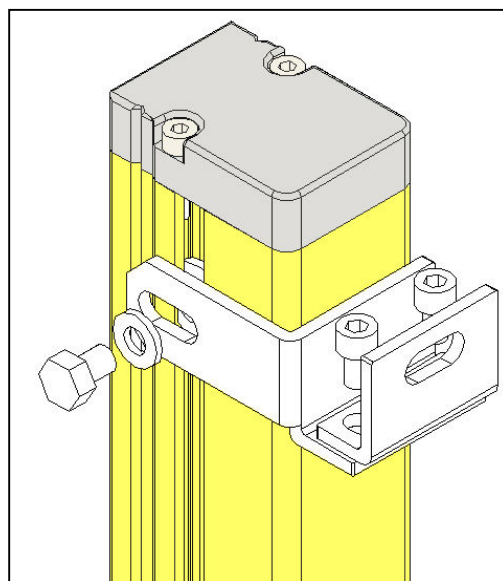

Brackets assembled on the barrier

NOTE :

To remove the flowing insert (in order to insert them in the opposite guide of the aluminium enclosure) you need to remove the end cap without the connector, unscrewing the two screws.

KIT OF BRACKETS “STDL”

supplied as optional to STVB kit

Is formed by a one bracket “L” shape that is used for the angular regulation of the barrier. The sliding insert inside the aluminium profile allows the sliding of the light curtain in the height to facilitate its correct positioning.

Content :

- 4 brackets GM
- 4 washers Ø6
- 4 screws M 6X8

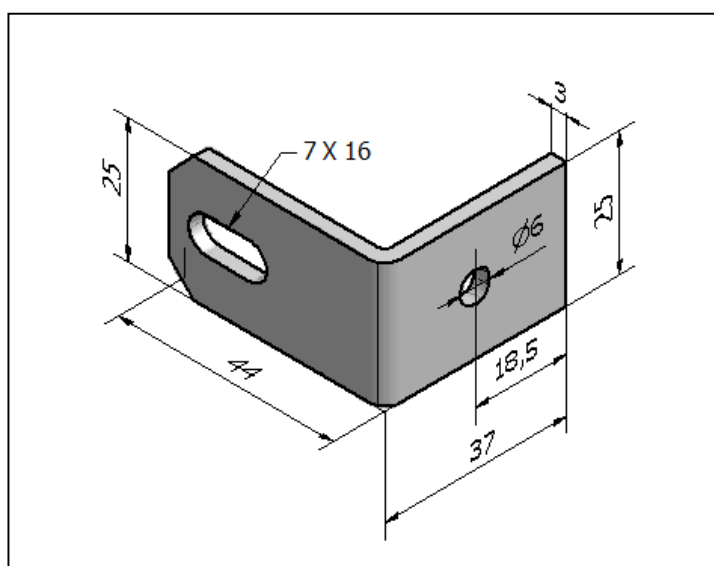

Brackets type GM

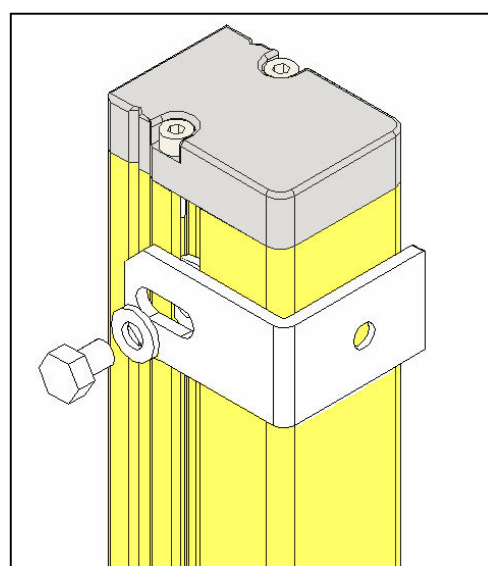

Brackets mounted on the barriers

NOTE :

To remove the flowing insert (in order to insert them in the opposite guide of the aluminium enclosure) you need to remove the end cap without the connector, unscrewing the two screws.

KIT OF BRACKETS "STGM"

Supplied on request as alternative to mod. STVB

This brackets kit allows to stay the light curtain in its place established by fixing one of the brackets to the side of the light curtain, is recommended when there are needs or difficulties in the installation of light curtains.

Content:

- 4 brackets type VB1
- 4 brackets type VB3
- 4 washers Ø6
- 4 screws M 6X8
- 8 screws M 5X8

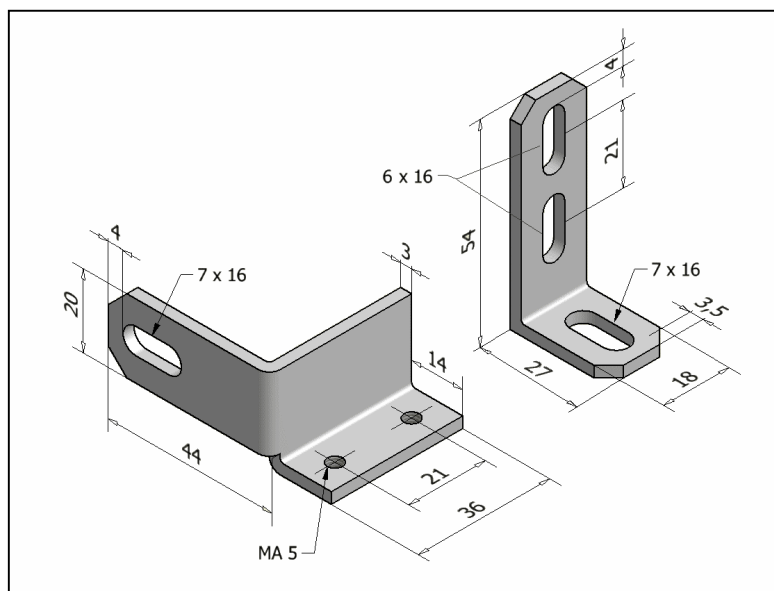

Brackets type VB1

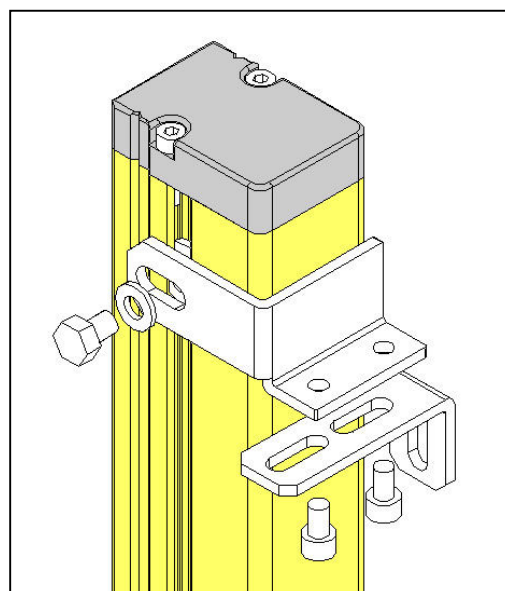



Brackets type VB 3 mounted on the barrier

NOTE:

To remove the flowing insert (in order to insert them in the opposite guide of the aluminium enclosure) you need to remove the end cap without the connector, unscrewing the two screws.

CONNECTION CABLES

Description		Code	
Connection cable Barrier - cabinet / relay module din rail			
M12 / 4 pins shielded connecting cable, right connector for TX	5m	E-84-5	
	10m	E-84-10	
M12 / 5 pins shielded connecting cable, right connector for RX a/d/e	5m	E-85-5	
	10m	E-85-10	
M12 / 8 pins shielded connecting cable, right connector for RX b/c/d/e	5m	E-88-5	
	10m	E-88-10	
M23 / 17 pins shielded connecting cable, right connector for RX f	5m	E-817-5	
Connection cable - to external relay module			
M12 / 4 pins shielded cable, 2 female right connector for TX-Rel 021/ 022	10m	E-94-10	
M12 / 5 pins shielded cable, 2 female right connector for RXa/d/e -Rel021/022	10m	E-95-10	
M12 / 8 pins shielded cable, 2 female right connector for RXb/c/d/e-Rel 021/022	10m	E-98-10	
M23 / 17pin shielded cable, 2 female right connector for RX f -Rel 021/ 022	10m	E-917-10	

RELAYS MODULE DIN RAIL



The following box, changes the static output of the light curtain, into relays output.
 This modules can be mounted on DIN rail and are matched with these model of barriers:
 EF b, EF d, EF e, EF f.
 This modules can be used only with light curtains with EDM function.

REL 011 relay module standard - example of connections

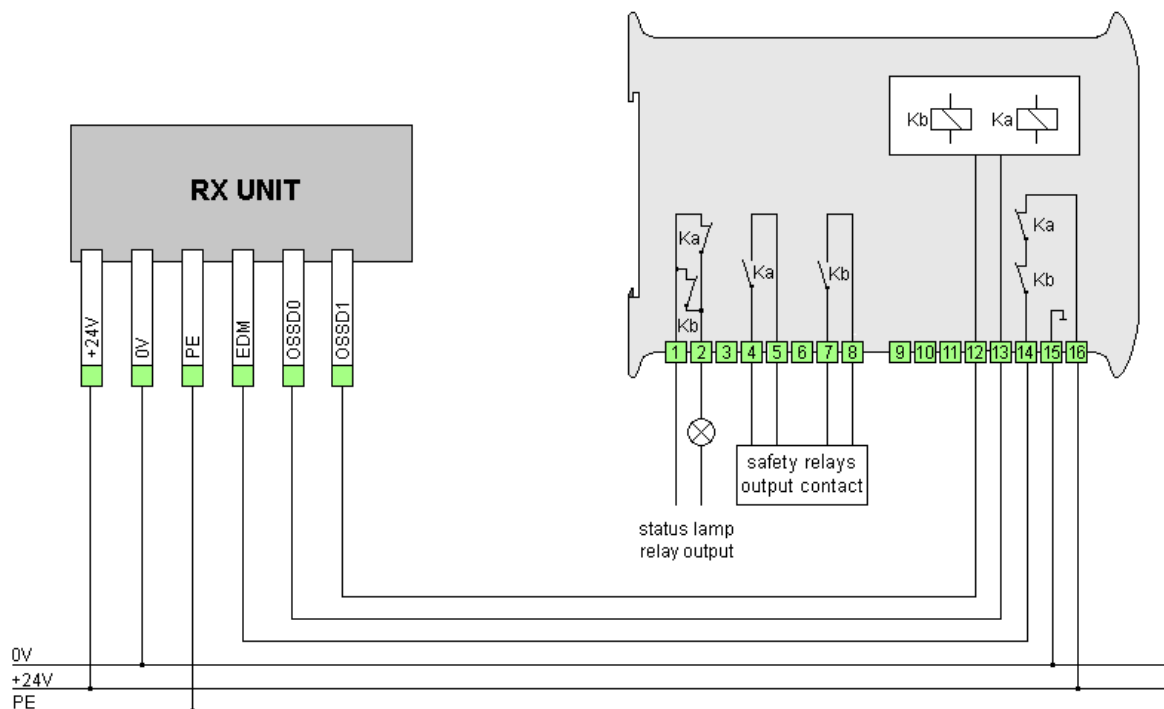

REL 012 relay module with blinking muting lamp - example of connections

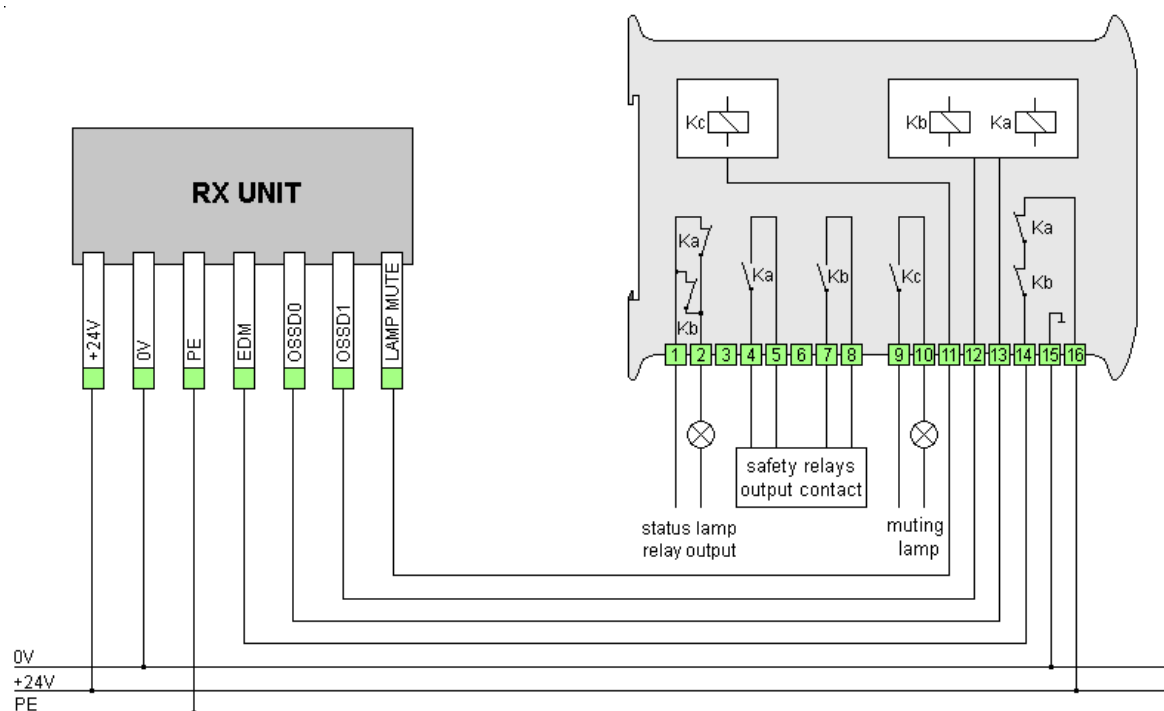

EXTERNAL MODULES

REL 022 E relays module with spring-key for manual reset and guard override; OSSD status and MUTING lamp for **EF e**



Example connection.

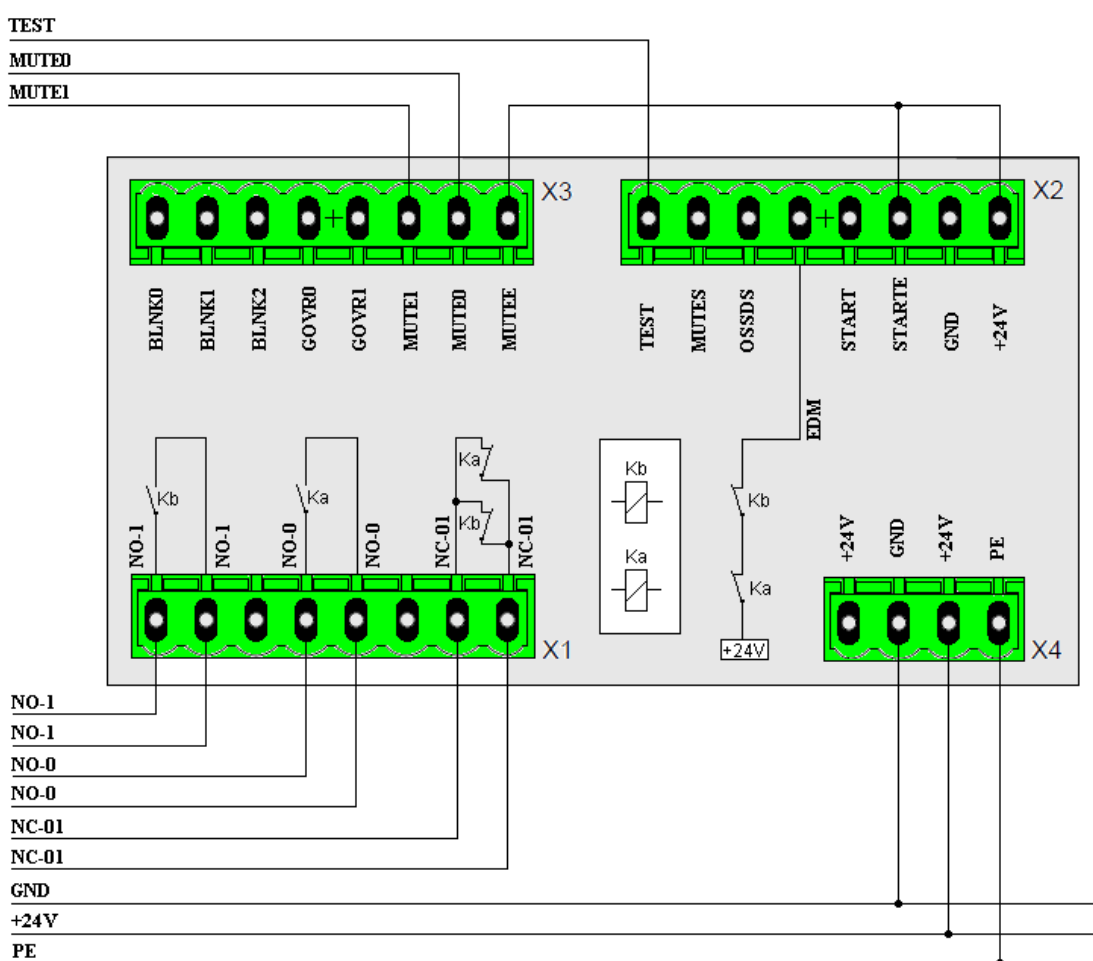

In this example the TEST signal is brought out of the box. The customer, with a push button N.O., can activate this function. The signal STARTE is connected to +24V, so the manual reset is selected. The signals MUTE0 and MUTE1 are brought out of the box and connected to the MUTING sensors. The MUTEE, signal for enable the MUTING function, is connected to +24V inside the box. The MUTING function is always active, is no possible de-activate it.

REL 022 F relays module with spring-key for manual reset and guard override; OSSD status and MUTING lamp for **EF f.**



Example connection.

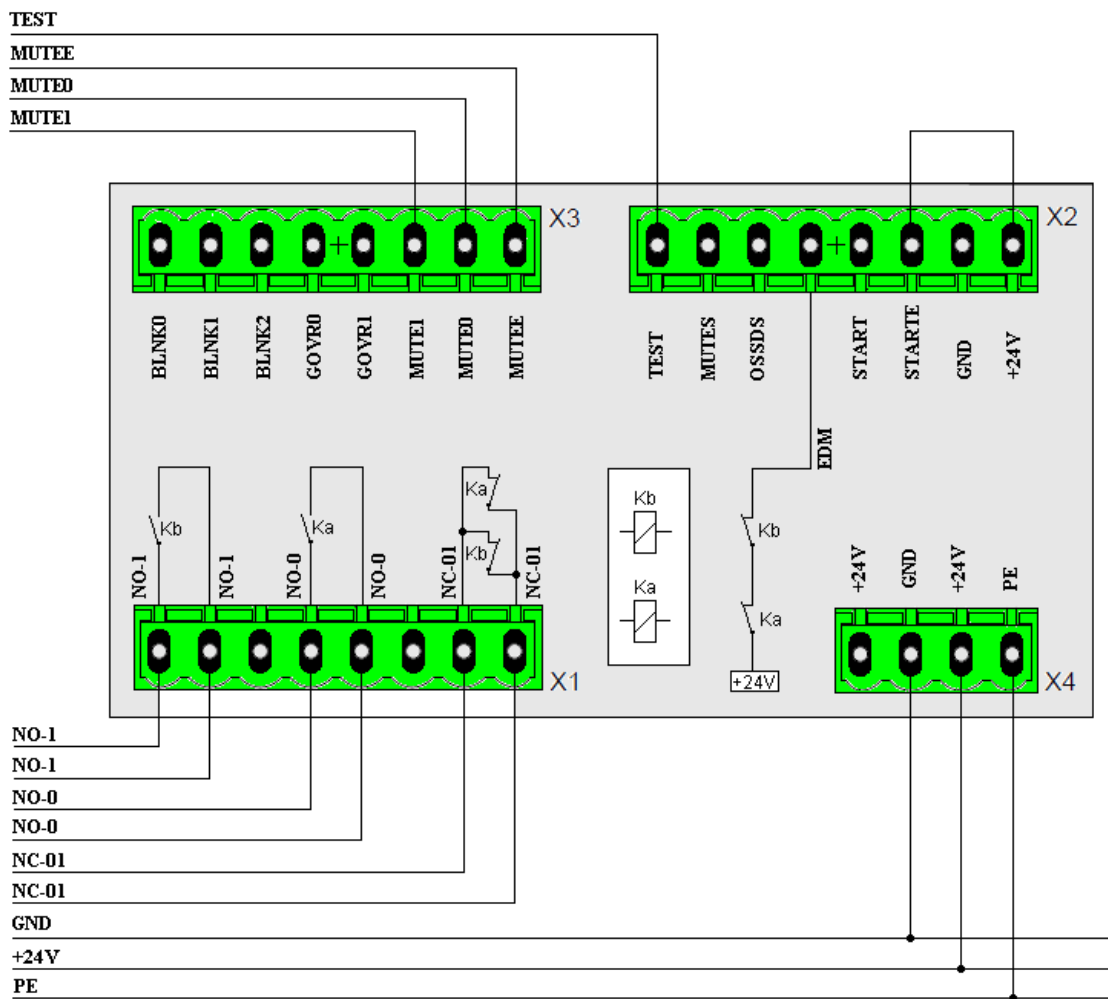

In this example the TEST signal is brought out of the box. The customer, with a push button N.O., can activate this function. The signal STARTE is connected to +24V, so the manual reset is selected. The signals MUTE0 and MUTE1 are brought out of the box and connected to the MUTING sensors. The MUTE, signal for enable the MUTING function, is also brought out of the box, so the customer can activate or not the MUTING function.

Warranty

A guarantee is provided for a period of 12 months from the delivery date and terminates at the expiration of this term, even if the materials have not been used for any reason.

Our company undertakes to repair or replace, during this period, free of charge, within the shortest possible time, those parts which owing to poor quality of material or defective workman-ship or inaccurate assembly should prove defective. This is providing that defects are not due to:

- wear and tear
- failure caused by inexperience or negligence
- unauthorized intervention or tampering
- overloads behind contract limits
- accidental causes or "force major"

These repairs or replacements shall be performed AT OUR WORKSHOP in MILANO.
Transport and workman-ship will be completely charged to purchaser.

Nothing will be owed to the purchaser for the time during which the plant may remain idle, nor shall he make claims or ask indemnity for charges, accidents or direct or indirect damages.

For anything else not specified or that becomes a subject of dispute, the ANIE (Italian Electrotechnical Industries Association) general sale conditions will be applied.

GREIN S.r.l. Milan

NOTE: characteristics and dimensions reported in this manual are for reference only and they can be subject to change without notice.

GREIN

“KEEPER”

Multiple beams safety barrier

GREIN



Via S. G. B. De la Salle 4/A 20132 Milano - MI Tel 02 26300140 Fax 02 26300711
www.grein.it | info@grein.it